

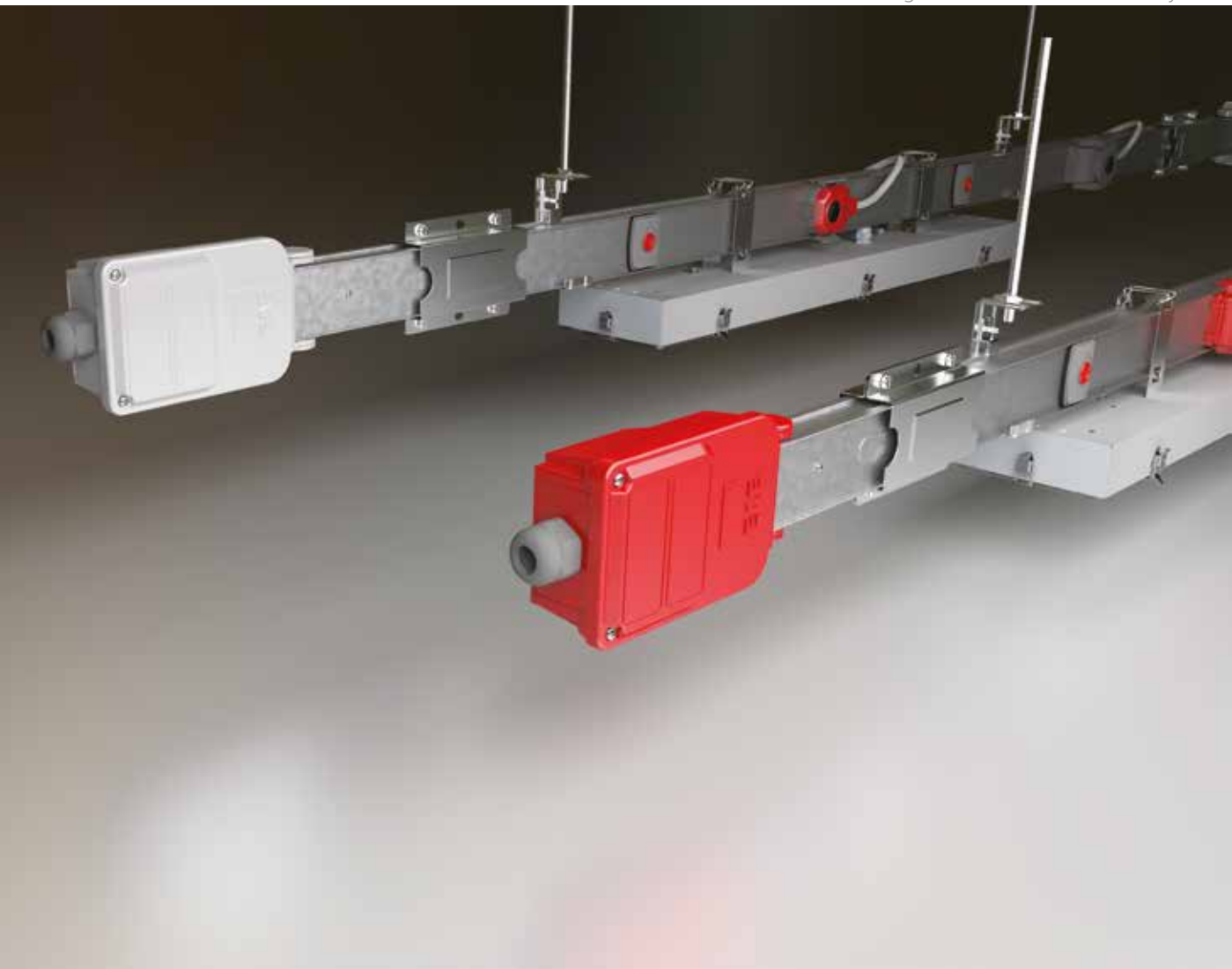

E-LINEKAM/KAP

KAM 25-32 A Lighting Busbar System
KAP 40-63 A Plug-in Busbar Distribution System



E-LINEKAM/KAP





CONTENTS

►► E-LINE KAM/KAP

General Description.....	2-3
Order Code System.....	4
Technical Characteristics.....	5
KAM Standard Busbars.....	6
KAM Standard Elements.....	7
KAM Tap Off Plugs.....	8
KAP Standard Busbars.....	9
KAP Standard Elements.....	10
KAP Tap Off Plugs.....	11
Hanger accessories for Busbar and Lighting Luminaries.....	12
Fixing and IP Accessories.....	13-15
Certificates.....	16
Declaration.....	17
Product Overview.....	18
Project Design Form.....	19-20

ELINEKAM-KAP

►► General Description



KAM and KAP Busbar Systems

KAM and KAP are busbar trunking systems, for lighting (KAM) and small Power (KAP), designed and certified in full compliance with international standards IEC 61439-1/6. Both systems have been tested and certified at the CESI Institute in accordance with the full type test cycle stated in the relevant IEC codes.

KAM and KAP group EAE standard busbar systems are used in buildings with a need of energy between 25...63 A.

KAM Group tap off plugs have been designed to feed the lighting fittings due to their characteristics.

KAP Group is used for the electrical energy distribution in areas where equipment such as hand machines and sewing machines requiring small amounts of energy are used.

Fast, Easy and Safe Installation

Mechanics and electricians are provided with a single action by driving the silver-plated spring contacts towards each other. It is enough to screw a single bolt to fix the locking.

Safety

The grounding conductors of the tap off plugs and tap off boxes first contact the busbar housing for safety and are disconnected last when being removed.

Full Insulation

Busbar conductors are coated with full length noncombustible insulation material. Even if the housing is damaged by heavy impact from the outside, full assurance is provided in terms of human safety.

5 Conductor Options

In addition to the phase and neutral conductors designed with a full section, a ground conductor option is also offered if needed.

Tin Plated Conductors

Electrolytic copper conductors are plated with full length tin to prevent CopperOxide formation. The contact resistances have been minimised with this feature.

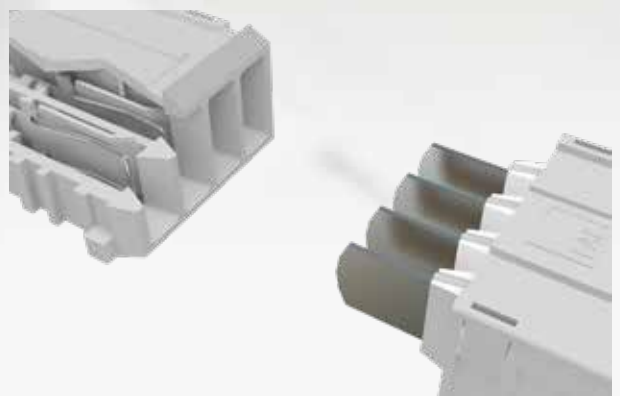

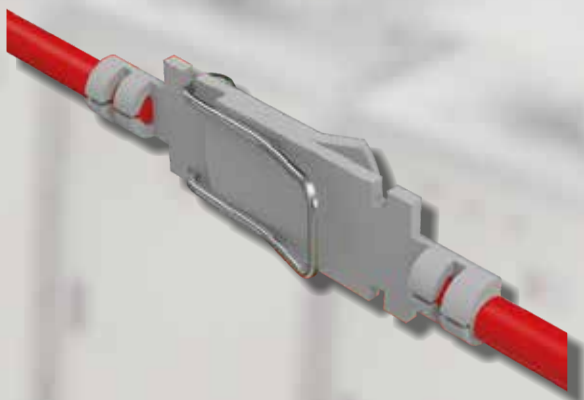

Silver-plated Joint Contacts

Busbar joint contacts and the contacts of all output units are silver plated. The silver-plated contact minimises the transresistance and prevents the contacts from overheating under the possible maximum loads.

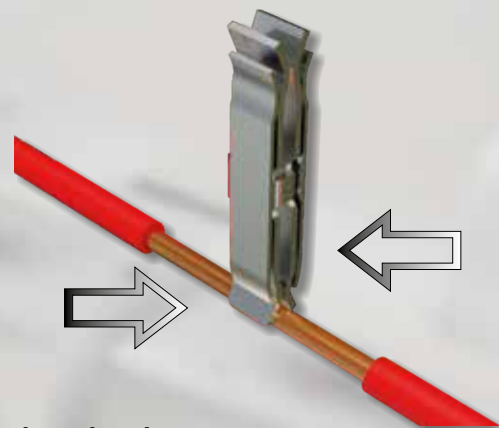

Tulip-shaped Spring Contacts

The contacts of tap off plugs and boxes are prepared as "Tulip-shaped Contacts". This compresses the conductor from two surfaces in the busbar. Silver plated contacts minimise contact transresistance.

Plug-in Points

Tap off points are provided every 75 cm as standard. Standard sizes with more plug-in points can be manufactured upon request.

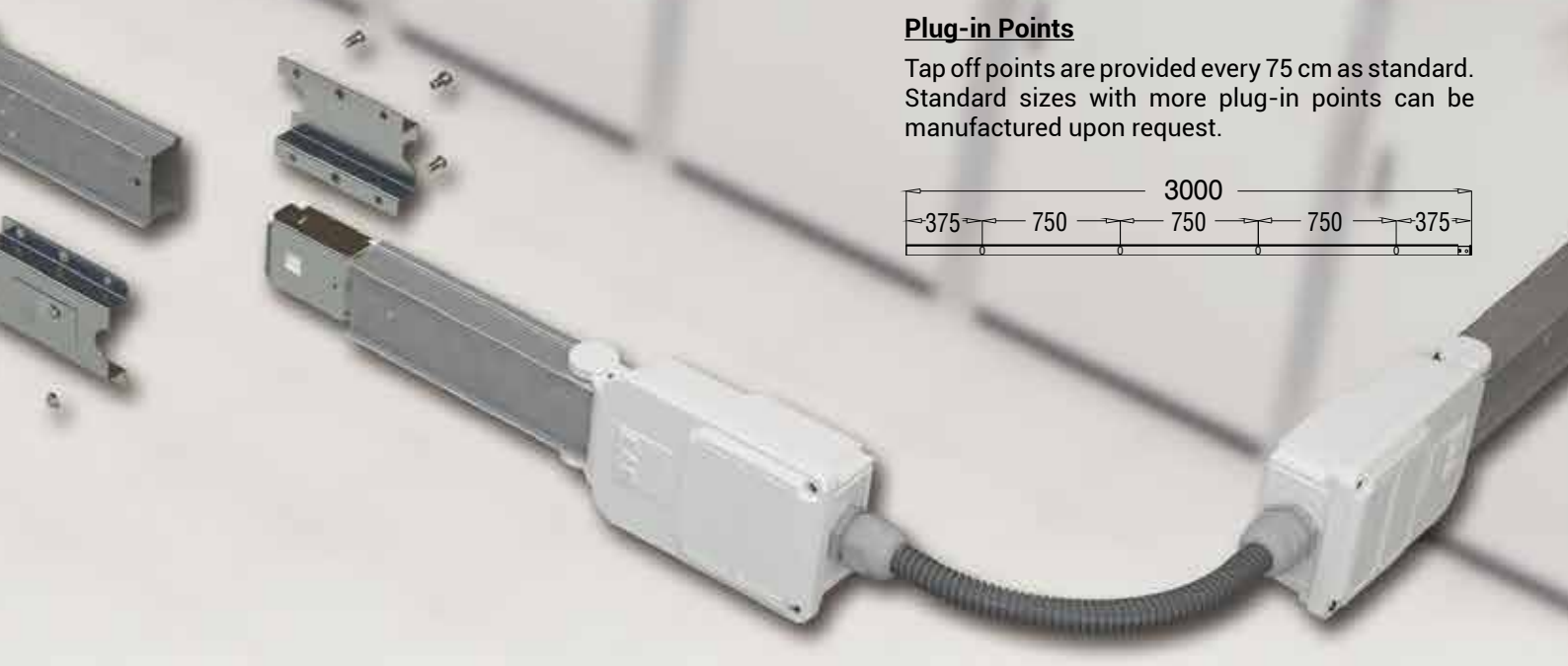
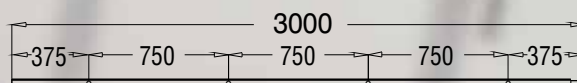

Coloured Covers Showing the Phase

The covers of E-Line KAM/KAP tap off plugs have been designed with different colours so that you can easily see which phase the armature is fed with.

High-Technology Product

EAE KAM- KAP Busbar systems are manufactured in accordance with ISO 9000 Standards and with certified quality assurance by using the latest manufacturing technologies in the world. The products are designed and certified in accordance with IEC 61439-1/6.

ELINEKAM/KAP

►► Order Code System

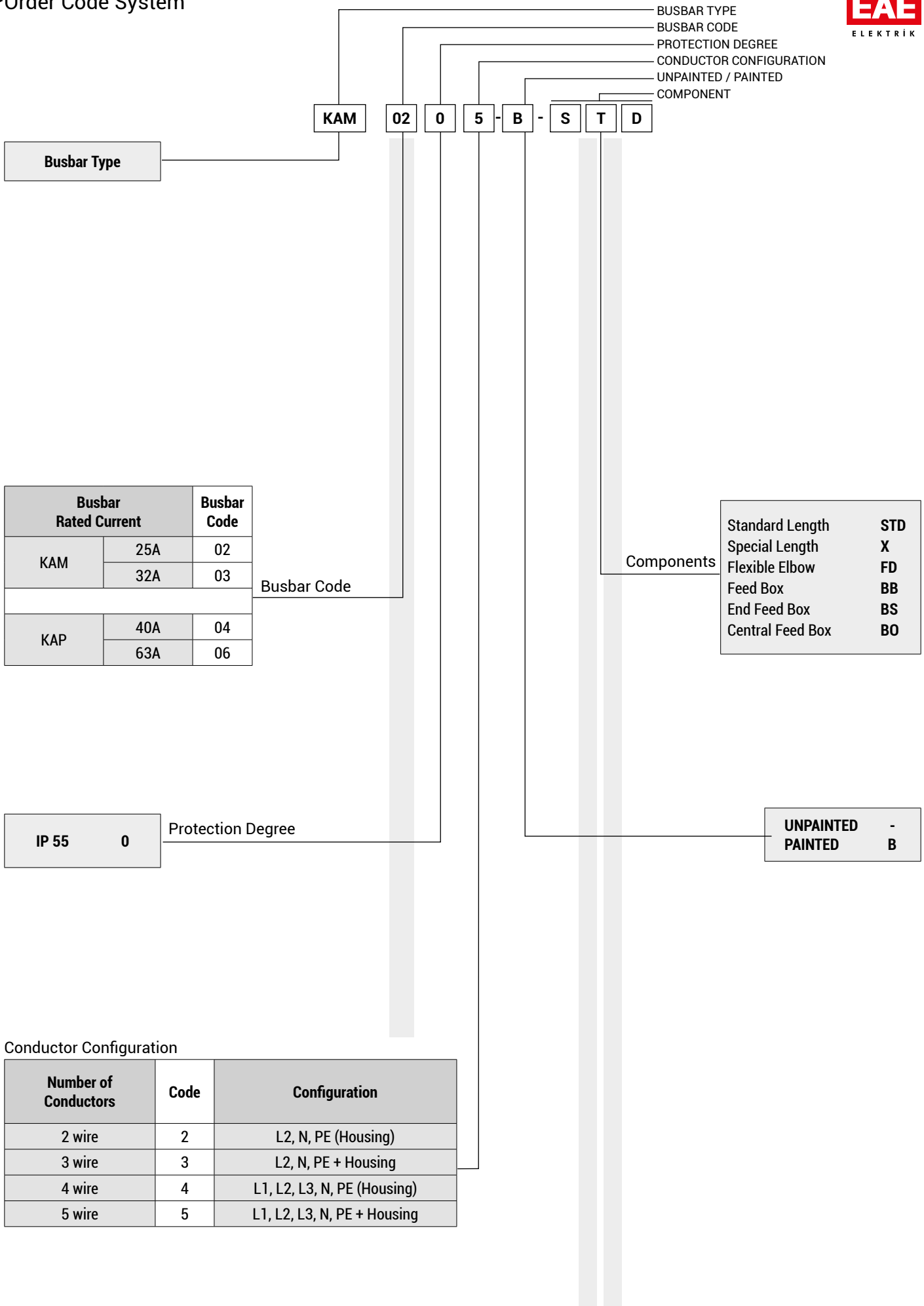

Rated Current	In	A	25	32	40	63
Busbar Code			KAM 02	KAM 03	KAP 04	KAP 06
Main Standards	IEC 61439-1/6, TS EN 61439-1/6					
Rated Isolation Voltage	Ui	V	500	500	690	690
Rated Frequency	f	Hz	50	50	50	50
Protection Degree	IP55					
Rated Short-time Withstand Current (0,1s)	Icw	kA _(rms)	2,27	2,72	3,4	4
Rated Peak Withstand Current	Ipk	kA	5	6	7,5	9
MEAN PHASE CONDUCTOR CHARACTERISTICS AT RATED CURRENT In						
Resistance at a conductor temperature of 20 °C	R ₂₀	mW/m	5,598	4,509	2,963	1,557
Resistance at an ambient air temperature of 35 °C	R	mW/m	6,612	5,444	3,518	1,914
Reactance (Independent from Temperature)	X	mW/m	0,488	0,377	0,229	0,155
Positive and negative sequence impedances at an ambient air temperature of 35 °C	Z	mW/m	6,630	5,458	3,525	1,920
Positive and negative sequence impedances at a conductor temperature of 20 °C	Z ₂₀	mW/m	5,619	4,524	2,972	1,565
Rated Power Loss at 35 °C		W/m	12,7	16,5	18,2	22,1
DC Resistance at a conductor temperature of 20 °C for Phases	R _{ort_{Ph}}	mW/m	5,534	4,333	2,871	1,462
DC Resistance at a conductor temperature of 20 °C for Neutral	R _N	mW/m	5,466	4,368	2,876	1,457
DC Resistance at a conductor temperature of 20 °C for PE	R _{PE}	mW/m	2,519	1,711	1,154	1,150
SECTIONS						
L1,L2,L3,N		mm ²	3,14	3,98	6,16	12,57
PE (5 Conductors)		mm ²	3,14	3,98	6,16	12,57
PE (Sheet Metal)		mm ²	96	96	96	96
PE (Cu Equivalent)		mm ²	9	9	9	9
Busbar Weight (4 Conductors)		kg/m	1,13	1,17	1,33	1,42
Busbar Weight (5 Conductors)		kg/m	1,17	1,19	1,41	1,48
MEAN FAULT-LOOP CHARACTERISTICS						
Zero-sequence Impedance						
Zero-sequence impedance at a conductor temperature of 20 °C	Z(0)b20phN	mW/m	22,53	18,40	12,13	6,06
Zero-sequence impedance at a conductor temperature of 20 °C (Housing)	Z(0)b20phPE	mW/m	12,30	10,32	7,09	5,62
Zero-sequence impedance at an ambient temperature of 35 °C	Z(0)bphN	mW/m	26,58	22,22	14,40	7,43
Zero-sequence impedance at an ambient temperature of 35 °C (Housing)	Z(0)bphPE	mW/m	14,50	12,44	8,39	6,87
Resistances and Reactances						
Resistance at a conductor temperature of 20 °C	Rb20phph	mW/m	10,92	8,82	5,89	2,98
Resistance at a conductor temperature of 20 °C	Rb20phN	mW/m	10,97	8,84	5,92	2,99
Resistance at a conductor temperature of 20 °C (Housing)	Rb20phPE	mW/m	7,60	6,18	4,21	2,81
Resistance at an ambient air temperature of 35 °C	Rbphph	mW/m	12,90	10,65	7,00	3,67
Resistance at an ambient air temperature of 35 °C	RbphN	mW/m	12,95	10,67	7,03	3,68
Resistance at an ambient air temperature of 35 °C (Housing)	RbphPE	mW/m	8,98	7,46	4,99	3,45
Reactance (Independent from temperature)	Xbphph	mW/m	0,61	0,11	0,25	0,21
Reactance (Independent from temperature)	XbphN	mW/m	0,63	0,37	0,10	0,24
Reactance (Independent from temperature)	XbphPE	mW/m	0,28	0,27	0,17	0,27

The maximum permitted load for the support of light fittings of the system is 15 kg. concentrated or 20 kg. distributed for a recommended support span of every 2 metres without any deformation of the housing.

Voltage Drop Calculation

Generally Voltage drop of a busbar system can be calculated with the following formula.

For single phase;

$$\Delta U = I \cdot 2L (R \cdot \cos \varphi + X \cdot \sin \varphi) \cdot 10^{-3} \text{ [V]}$$

For three phase ;

$$\Delta U = \sqrt{3} \cdot I \cdot L (R \cdot \cos \varphi + X \cdot \sin \varphi) \cdot 10^{-3} \text{ [V]}$$

ΔU = Voltage Drop [V]

I = Rated Current [A]

L = Length of Line [m]

R = Resistance [mΩm]

X = Reactance [mΩm]

Standard Busbars

Current (A)	Description	Conductors	Phase	Unpainted Order Code	Painted Order Code
25	KAM 0205 Standard Busbars	5	L1, L2, L3, N, (PE+Housing)	3025050	3025051
	KAM 0204 Standard Busbars	4	L1, L2, L3, N, (+Housing)	3025046	3025047
	KAM 0203 Standard Busbars	3	L2, N, (PE+Housing)	3025029	3025030
	KAM 0202 Standard Busbars	2	L2, N, (+Housing)	3025027	3025028
32	KAM 0305 Standard Busbars	5	L1, L2, L3, N, (PE+Housing)	3025058	3025059
	KAM 0304 Standard Busbars	4	L1, L2, L3, N, (+Housing)	3025054	3025055
	KAM 0303 Standard Busbars	3	L2, N, (PE+Housing)	3025033	3025034
	KAM 0302 Standard Busbars	2	L2, N, (+Housing)	3025031	3025032

*Special straight length busbars are manufactured as standard as 1 m., 1,5 m. and 2 m.

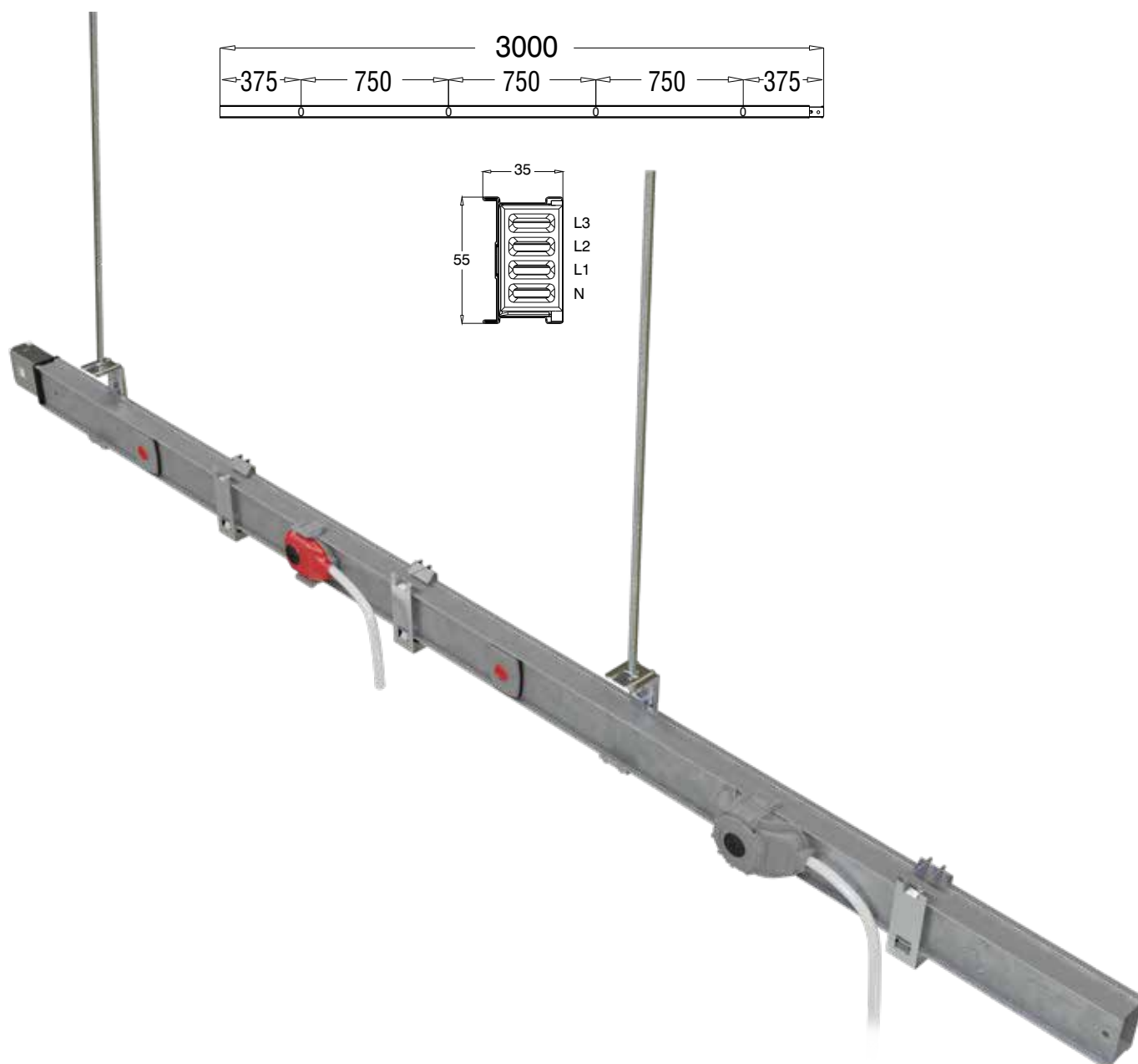

Feed Box*

Current (A)	Description	Busbars	Unpainted Order Code	Painted Order Code
25	KAM 0205 BB Feed Box	KAM 0205 KAM 0204 KAM 0203 KAM 0202	3025062	3025063
32	KAM 0305 BB Feed Box	KAM 0305 KAM 0304 KAM 0303 KAM 0302	3025064	3025065

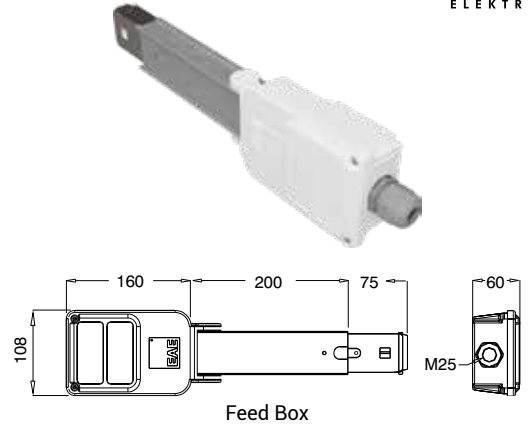

End Feed Box*

Current (A)	Description	Busbars	Unpainted Order Code	Painted Order Code
25	KAM 0205 BS End Feed Box	KAM 0205 KAM 0204 KAM 0203 KAM 0202	3025066	3025067
32	KAM 0305 BS End Feed Box	KAM 0305 KAM 0304 KAM 0303 KAM 0302	3025068	3025069

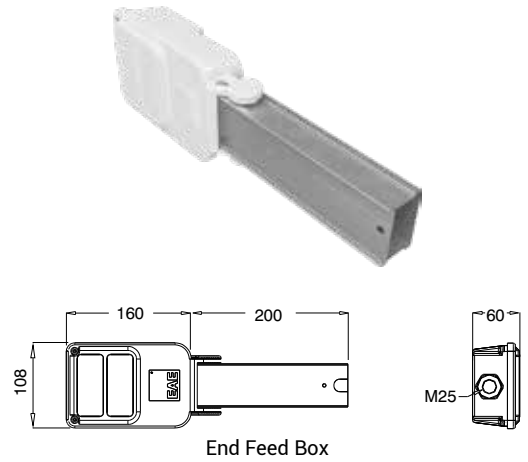

Central Feed Box*

Current (A)	Description	Busbars	Unpainted Order Code	Painted Order Code
25	KAM 0205 BO Central Feed Box	KAM 0205 KAM 0204 KAM 0203 KAM 0202	3025070	3025071
32	KAM 0305 BO Central Feed Box	KAM 0305 KAM 0304 KAM 0303 KAM 0302	3025072	3025073

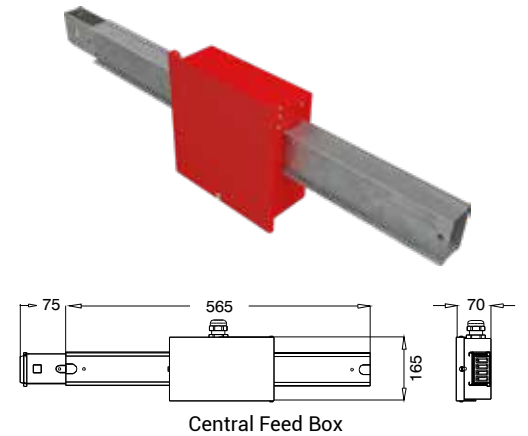

Flexible Elbow

Current (A)	Description	Tap Off Plugs	Unpainted Order Code	Painted Order Code
25	KAM 0205-FD Flexible Elbow	KAM 0205 KAM 0204 KAM 0203 KAM 0202	3024417	3024418
32	KAM 0305-FD Flexible Elbow	KAM 0305 KAM 0304 KAM 0303 KAM 0302	3024415	3024416

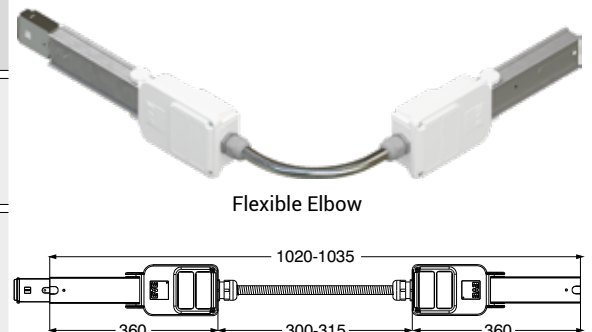

* With PE Conductor and M25 Gland as standard.
End Closer is supplied together with the feed unit.

Tap-off Plug (B)

Current (A)	Description	Cable Length / Type		Phase	Properties	Order Code	
		Halojen Free	Standard (PVC)			Halojen Free	Standard (PVC)
10	KAM 10 - B Tap-off Plug L1	0,75 m.	0,75 m.	L1, N, PE	With Black Cover	3024549	3086986
	KAM 10 - B Tap-off Plug L1	052XZ1-F	NYMHY	L2, N, PE	With Yellow Cover	3024548	3086988
	KAM 10 - B Tap-off Plug L1	3x1,5 mm ² Cable(*)	3x1,5 mm ² Cable(*)	L3, N, PE	With Blue Cover	3024547	3086990

Tap-off Plug (BL)**

Current (A)	Description	Cable Length / Type	Phase	Properties	Order Code
					Halojen Free
10	KAM 10 - BL Tap-off Plug L1	0,75 m.	L1, N, PE	With Black Cover	3134596
	KAM 10 - BL Tap-off Plug L2	052XZ1-F	L2, N, PE	With Yellow Cover	3134597
	KAM 10 - BL Tap-off Plug L3	3x0,75 mm ² Cable(*)	L3, N, PE	With Blue Cover	3134598

* Plugs with different length cable available upon request.

** It is used only for lighting fittings supply in lighting circuits.

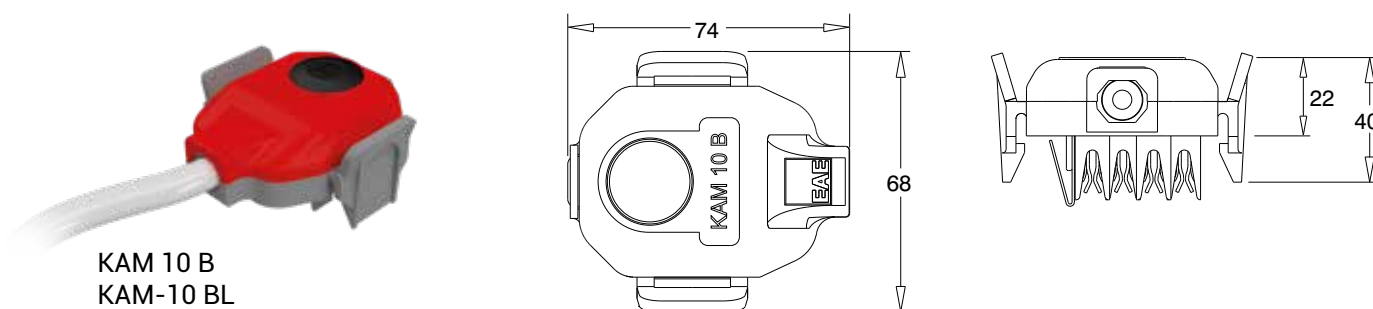

KAM 10 B
KAM-10 BL

Tap Off Plugs

Current (A)	Description	Cable Length	Phase	Properties	Order Code
16	KAM 16 - FS Tap-off Plug L1	-	L1, N, PE	With 5x20 cylindrical fuseholders. Max diameter of feeder cable is Ø 11mm.**	3024612
	KAM 16 - FS Tap-off Plug L2	-	L2, N, PE		3024611
	KAM 16 - FS Tap-off Plug L3	-	L3, N, PE		3024610
	KAM 16 - FS Tap-off Plug L123	-	L1, L2, L3, N, PE		3024609
16	KAM 16 - K Tap-off Plug L1	-	L1, N, PE	Without Fuses. Max diameter of feeder cable is Ø 11mm.	3024616
	KAM 16 - K Tap-off Plug L2	-	L2, N, PE		3024615
	KAM 16 - K Tap-off Plug L3	-	L3, N, PE		3024614
	KAM 16 - K Tap-off Plug L123	-	L1, L2, L3, N, PE		3024613

** The cylindrical fuse plug is not included.

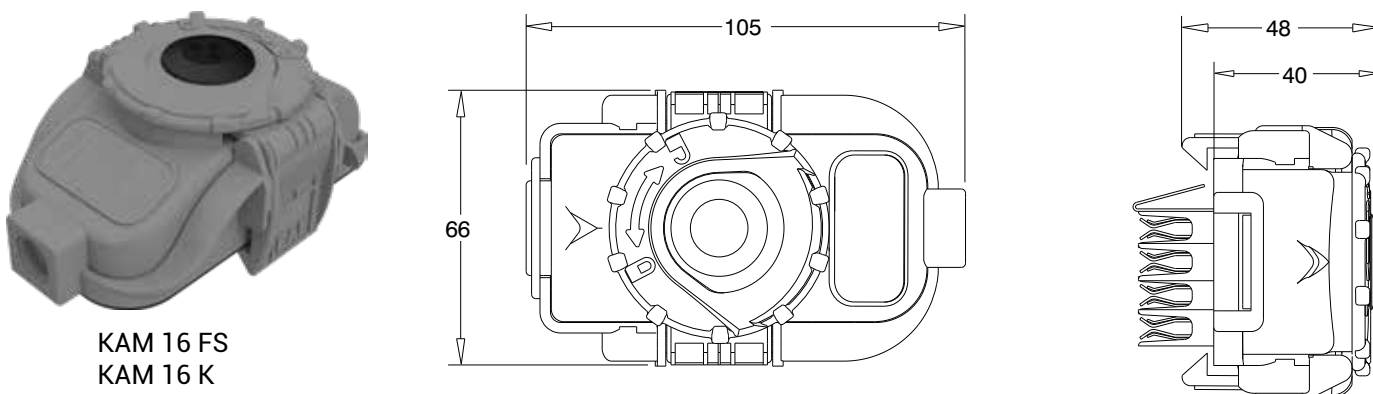

KAM 16 FS
KAM 16 K

Standard Busbars

Current (A)	Description	Conductors	Phase	Unpainted Order Code	Painted Order Code
40	KAP 0405 Standard Busbars	5	L1, L2, L3, N, (PE+Housing)	3025076	3025077
	KAP 0404 Standard Busbars	4	L1, L2, L3, N, (+Housing)	3025074	3025075
	KAP 0403 Standard Busbars	3	L2, N, (PE+Housing)	3025086	3025087
	KAP 0402 Standard Busbars	2	L2, N, (+Housing)	3025088	3025089
63	KAP 0605 Standard Busbars	5	L1, L2, L3, N, (PE+Housing)	3025080	3025081
	KAP 0604 Standard Busbars	4	L1, L2, L3, N, (+Housing)	3025078	3025079
	KAP 0603 Standard Busbars	3	L2, N, (PE+Housing)	3025082	3025083
	KAP 0602 Standard Busbars	2	L2, N, (+Housing)	3025084	3025085

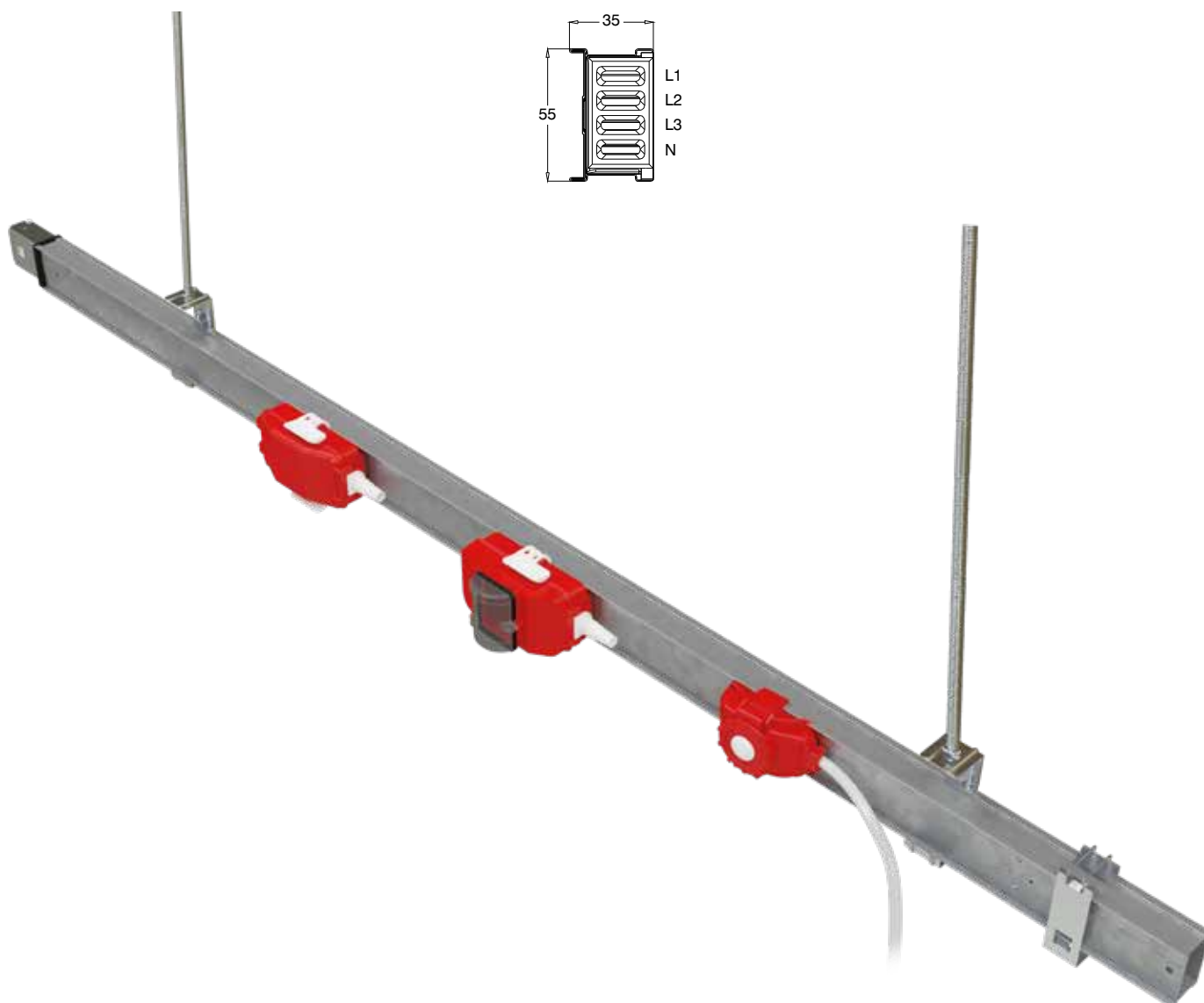
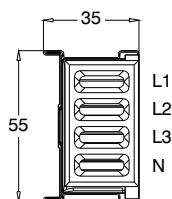
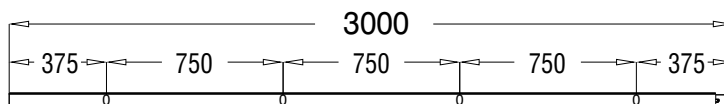

Feed Box

Current (A)	Description	Busbars	Unpainted Order Code	Painted Order Code
40	KAP 0405 BB Feed Box	KAP 0405 KAP 0404 KAP 0403 KAP 0402	3025098	3025099
63	KAP 0605 BB Feed Box	KAP 0605 KAP 0604 KAP 0603 KAP 0602	3025100	3025101

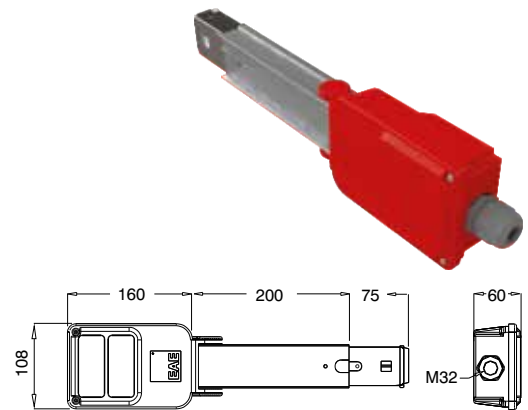

Feed Box

End Feed Box

Current (A)	Description	Busbars	Unpainted Order Code	Painted Order Code
40	KAP 0405 BS End Feed Box	KAP 0405 KAP 0404 KAP 0403 KAP 0402	3025102	3025103
63	KAP 0605 BS End Feed Box	KAP 0605 KAP 0604 KAP 0603 KAP 0602	3025104	3025105

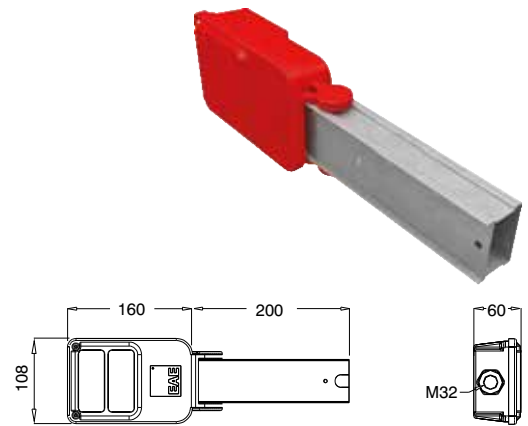

End Feed Box

Central Feed Box

Current (A)	Description	Busbars	Unpainted Order Code	Painted Order Code
40	KAP 0405 BO Central Feed Box	KAP 0405 KAP 0404 KAP 0403 KAP 0402	3024960	3024961
63	KAP 0605 BO Central Feed Box	KAP 0605 KAP 0604 KAP 0603 KAP 0602	3024962	3024963

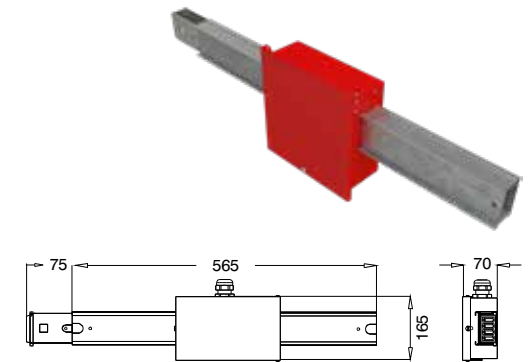

Central Feed Box

Flexible Elbow

Current (A)	Description	Busbars	Unpainted Order Code	Painted Order Code
40	KAP 0405-FD Flexible Elbow	KAP 0405 KAP 0404 KAP 0403 KAP 0402	3024413	3024414
63	KAP 0605-FD Flexible Elbow	KAP 0605 KAP 0604 KAP 0603 KAP 0602	3024411	3024412

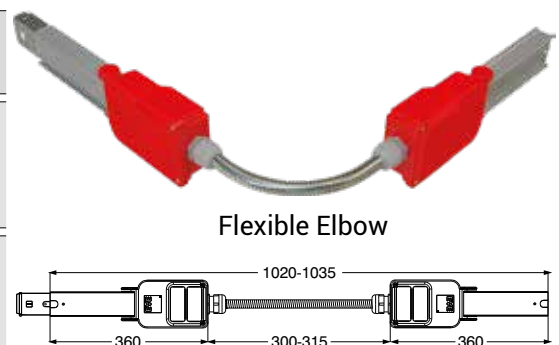

Flexible Elbow

* With PE Conductor and Special EAE Gland M32 as standard.

Tap Off Plugs

Current (A)	Description	Phase	Properties	Order Code
16	KAP 16 - FS Tap-off Plug L1	L1, N, PE	5 x 20 Fuse holders. Max diameter of feeder cable is \varnothing 11 mm.	3024556
	KAP 16 - FS Tap-off Plug L2	L2, N, PE		3024555
	KAP 16 - FS Tap-off Plug L3	L3, N, PE		3024554
	KAP 16 - FS Tap-off Plug L123	L1, L2, L3, N, PE		3024557
16	KAP 16 - K Tap-off Plug L1	L1, N, PE	Without Fuses Max diameter of feeder cable is \varnothing 11 mm.	3024552
	KAP 16 - K Tap-off Plug L2	L2, N, PE		3024551
	KAP 16 - K Tap-off Plug L3	L3, N, PE		3024550
	KAP 16 - K Tap-off Plug L123	L1, L2, L3, N, PE		3024553



KAP 16 FS
KAP 16 K

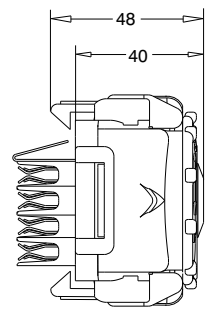
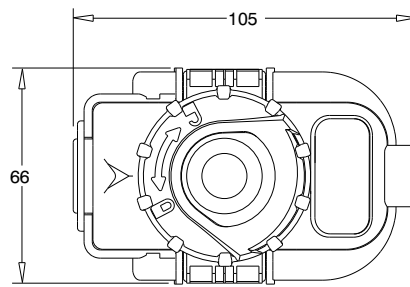

Tap Off Plugs

Current (A)	Description	Phase	Properties	Order Code
32	KAP 32 - Empty Tap Off Box*	L1, L2, L3, N, PE	10 x 38 Fuse cylindrical holders Max diameter of feeder cable is \varnothing 20 mm.**	3025109
	KAP 32 - Tap Off Box 10x38 fuse holders**	L1, L2, L3, N, PE		3025108

* Tap off box can be fitted with MCB's of different ratings and brands.

** The cylindrical fuse plug is not included.



KAP 32

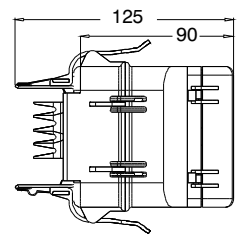
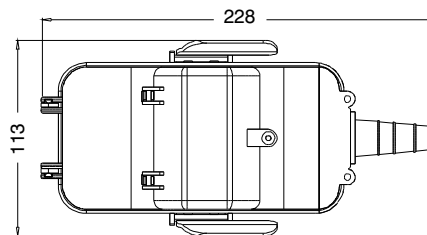

KAP 32 FS

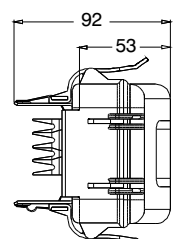
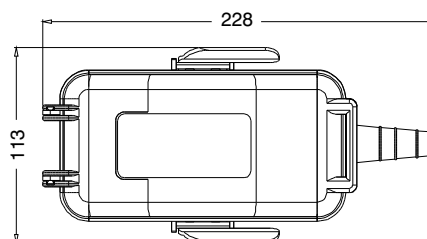

ELINEKAM/KAP

►► Hanger accessories for Busbar and Lighting Luminaries

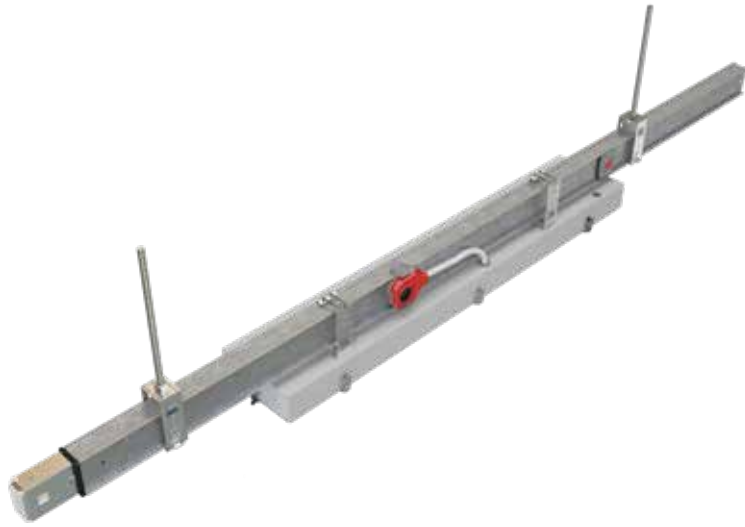

Description	Unpainted Order Code	Painted Order Code
U Type Fixing Unit	1004874	2037294

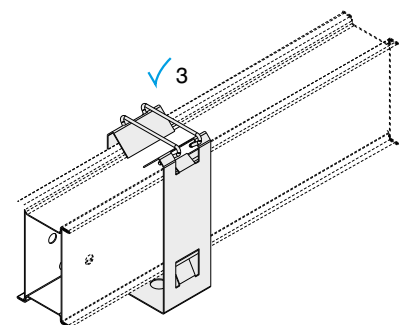
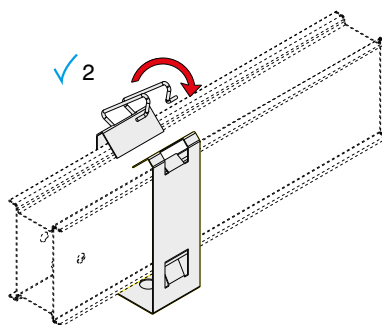
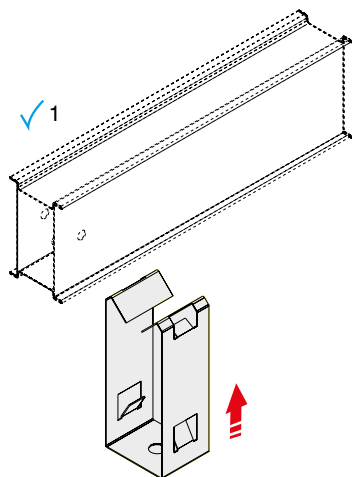
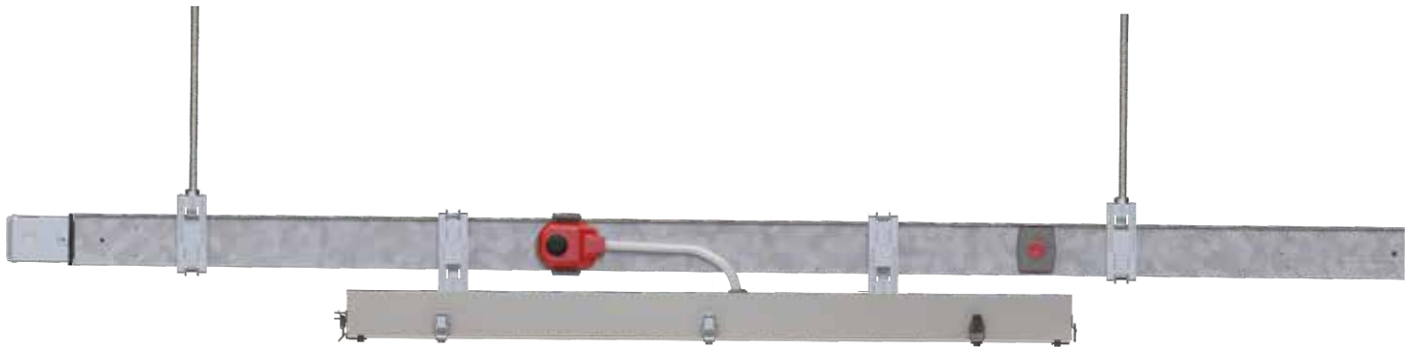
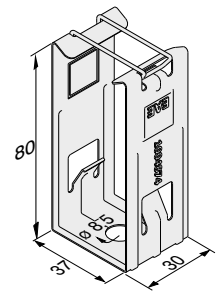

ELINEKAM/KAP

►► Hanger accessories for Busbar and Lighting Luminaries

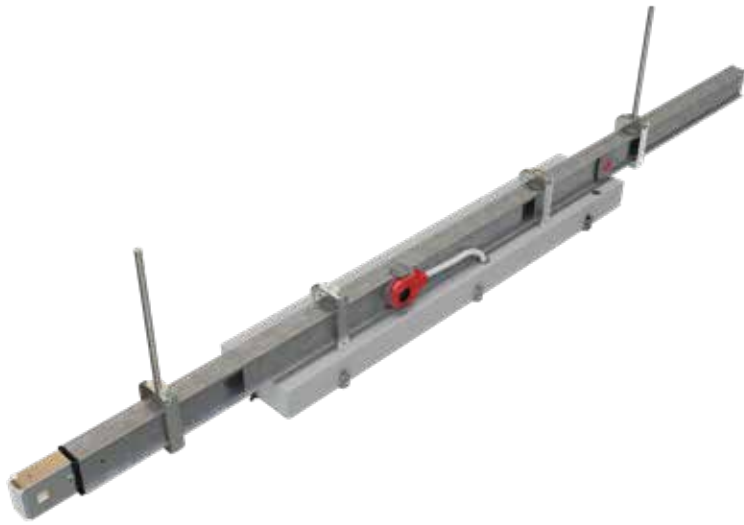

Description	Unpainted Order Code	Painted Order Code
L Type Fixing Unit	1004190	2037293

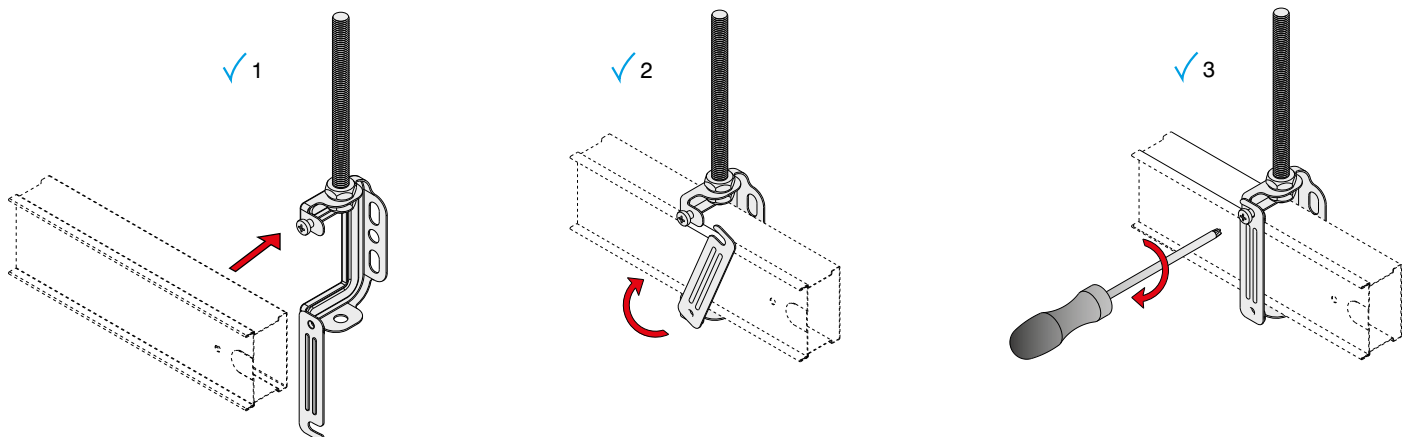
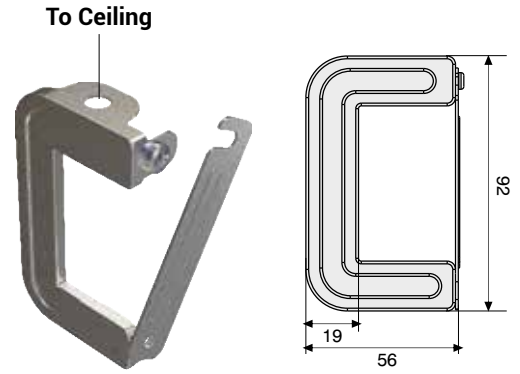

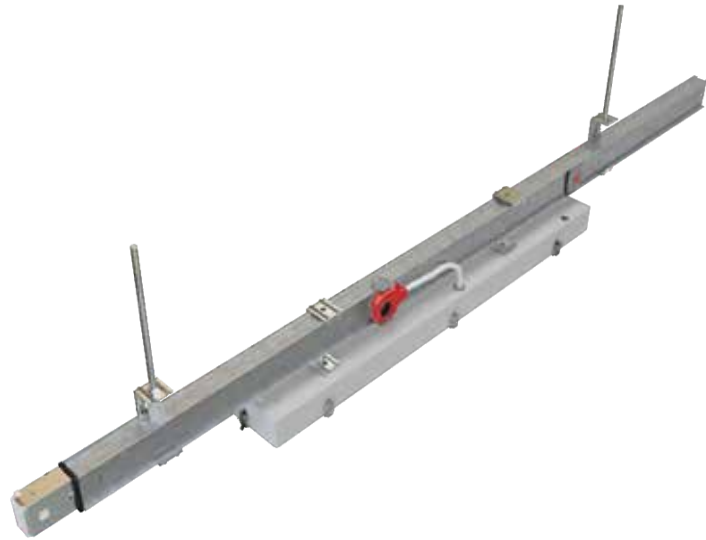

Description	Unpainted Order Code	Painted Order Code
L Type Fixing Unit	1004283	2037295

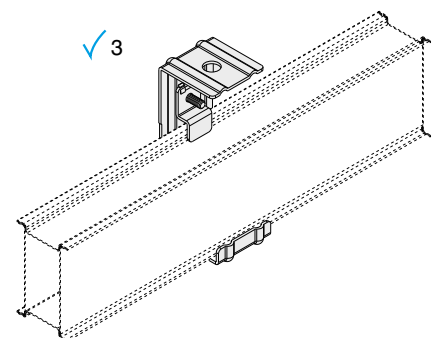
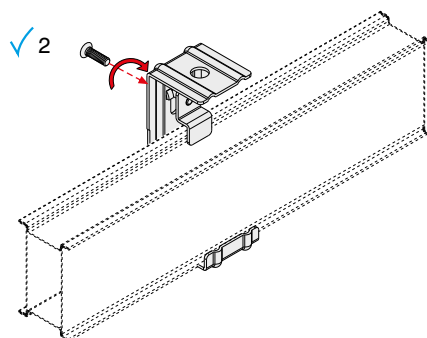
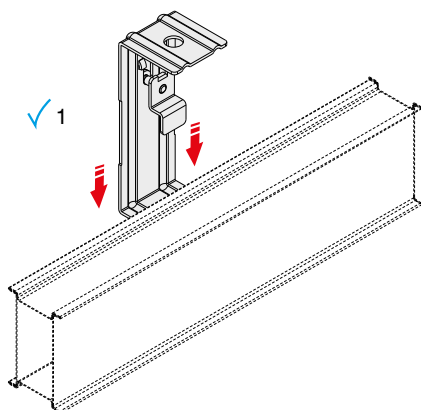
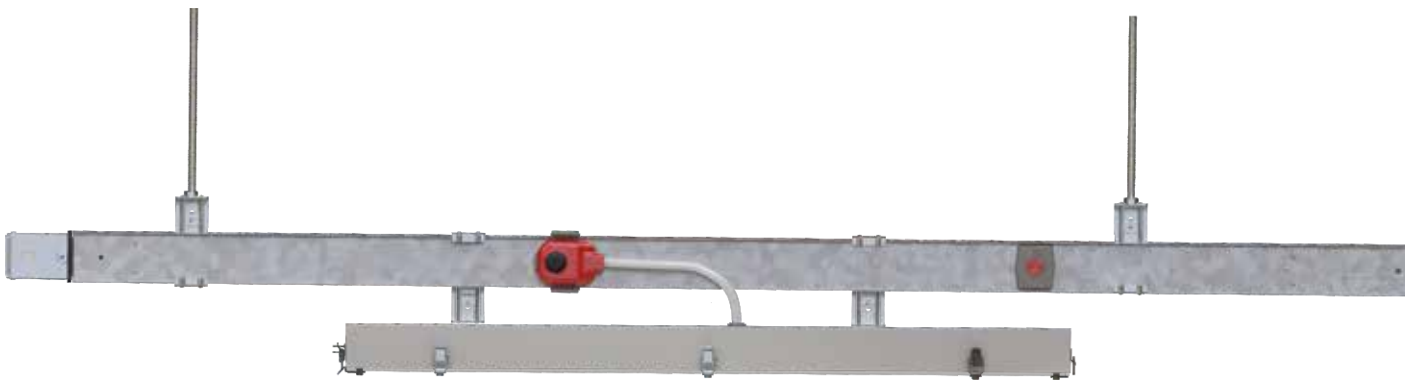
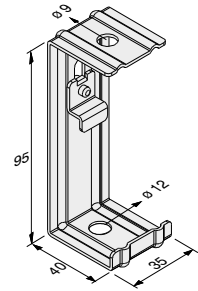

Fixing unit "U" type

Description	Unpainted Order Code	Painted Order Code
KA - TPU TPU Fixing unit "U" type	3025158	3025159

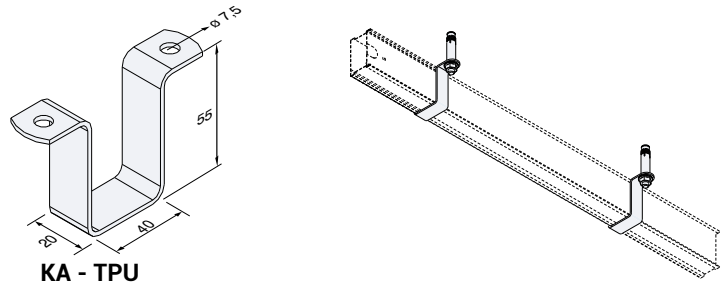

KA - TPU

Side Wall Support

Description	Unpainted Order Code	Painted Order Code
KA-TD Side Wall Support	3025106	3025107

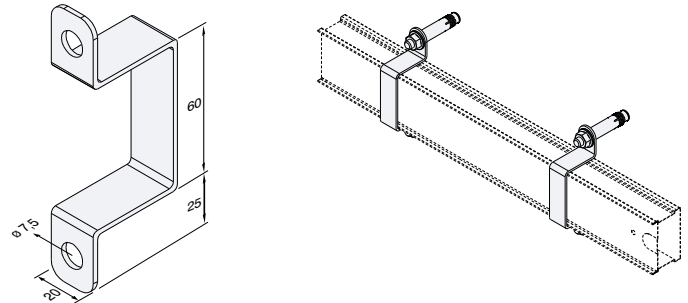

KA-TD Side Wall Support

KAM-KAP Joint Support

Description	Unpainted Order Code	Painted Order Code
KAM-KAP Joint Support	3025160	3025161

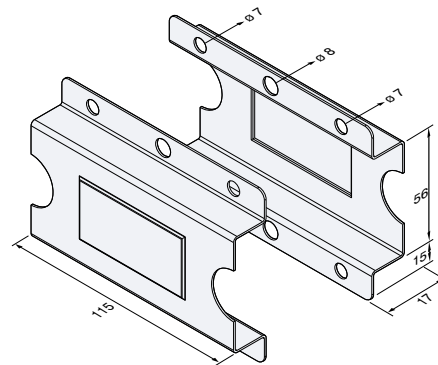

KAM-KAP Joint Support

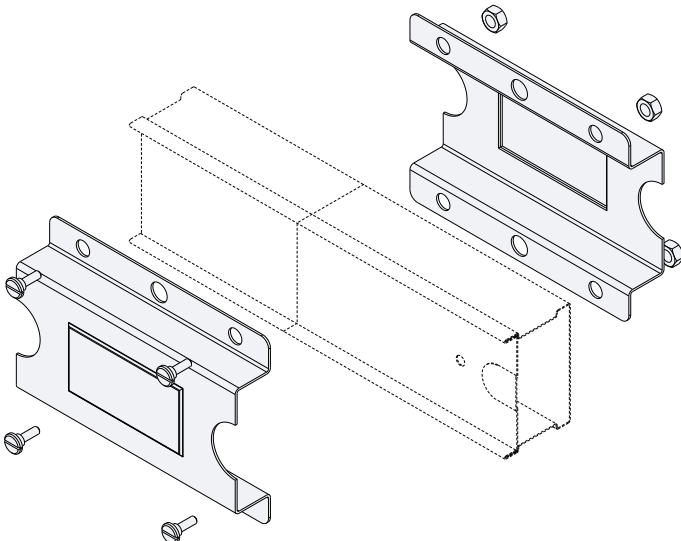

CE DECLARATION OF CONFORMITY

Product Group E-Line KAM-KAP Busbar Energy Distribution System

Manufacturer EAE Elektrik Asansor End. Insaat San. ve Tic. A.S.
Akcaburgaz Mahallesi, 3114. Sokak,
No:10 34522 Esenyurt-Istanbul

The objects of the declaration described below is in conformity with the relevant Union harmonisation legislation. This declaration of conformity is issued under the sole responsibility of the manufacturer.

Standard :**TS EN 61439-6**

Low-voltage switchgear and controlgear assemblies - Part 6: Busbar trunking systems

CE - Directive:

2014/35/EU "The Low Voltage Directive"

2014/30/EU "Electromagnetic Compatibility (EMC) Directive"

2011/65/EU "Restriction of the use of certain hazardous substances (RoHS)"

Technical Document Preparation Official ;

EAE Elektrik Asansor End. Insaat San. ve Tic. A.S.
Akcaburgaz Mahallesi, 3114. Sokak, No:10 34522 Esenyurt-Istanbul

Emre GÜRLEYEN

Date

08.03.2021

Document Authorized Signatory

Elif Gamze KAYA OK
Deputy General Manager



25A - 63A PLUG-IN BUSBAR SYSTEMS PRODUCT OVERVIEW (E-Line KAM / KAP)

- 1- The standard busbar system must be manufactured in accordance with IEC 61439-6. It must have type test certificates from international test laboratories for each current level.
- 2- The standard busbar system must be manufactured in facilities with the ISO 9001 quality system and ISO 14001 environment system certificates.
- 3- The nominal insulation voltage of the standard busbar system must be KAM(500V), KAP(690V).
- 4- The standard busbar system must be tin plated and have a copper conductor at current values between 25A and 63A.
- 5- The conductors of the standard busbar system must have full-length insulation. It must be peeled off to create a contact area at the plug-in points.
- 6- The standard busbar system must have the following number of conductors and phase configuration.
 - a) 2 Wire: L1 / N / Housing
 - b) 3 Wire: L1 / N / PE + Housing (PE Conductor and Housing Combined)
 - c) 4 Wire: L1 / L2 / L3 / N / Housing
 - d) 5 Wire: L1 / L2 / L3 / N / PE + Housing (PE Conductor and Housing Combined)The housing must be used as the ground conductor.
- 7- There are 4 plug-in points on the 3 m standard length of the standard busbar system. The number of fenestrations can be increased on special request. There must be a protection cover on the plug-in windows.
- 8- There should be insulator wedges to carry the conductors at the plug-in points.
- 9- The conductors must be electrolytic copper, and tin plated over the entire length.
- 10- The additional joints of the busbar system elements must have a plug-in structure. Joint contacts of the conductors must be silver plated. Loosening of the joint must be prevented with the double-sided spring pressure method. A joint structure with terminals that will allow loosening must not be used.
- 11- Busbar channels must have the IP 55 protection rating.
- 12- The housing of the standard busbar system must be manufactured with an 0.50 mm thick galvanised sheet. It can be produced painted with electrostatic oven-baked paint of RAL 7038 colour by the manufacturer if requested.
- 13- The contacts of the tap off plugs and boxes must be silver-plated and have tulip-shaped spring contacts that will press on the conductors inside the busbar from both surfaces.
- 14- It must have standard bracket and fixing elements in accordance of the external structure of the busbar system and these must be produced by the manufacturer.

EAE Elektrik A.S.
Head Office
Akcaburgaz Mahallesi,
3114. Sokak, No:10 34522
Esenyurt - Istanbul - TURKEY
Tel: +90 (212) 866 20 00
Fax: +90 (212) 886 24 20

EAE DL 3 Factory
Busbar
Gebze IV Istanbul Makine ve
Sanayicileri
Organize Bolgesi, 6. Cadde,
No: 6 41455 Demirciler Koyu,
Dilovası - Kocaeli - TURKEY
Tel: +90 (262) 999 05 55
Fax: +90 (262) 502 05 69

Please visit our website for the updated version of our catalogues.
www.eaeelectric.com



IEC 61439-6



Catalog 06-En. / Rev 16 500 Ad. 04/08/2023
S.S.

EAE has full right to make any revisions or changes on this catalogue without any prior notice.