

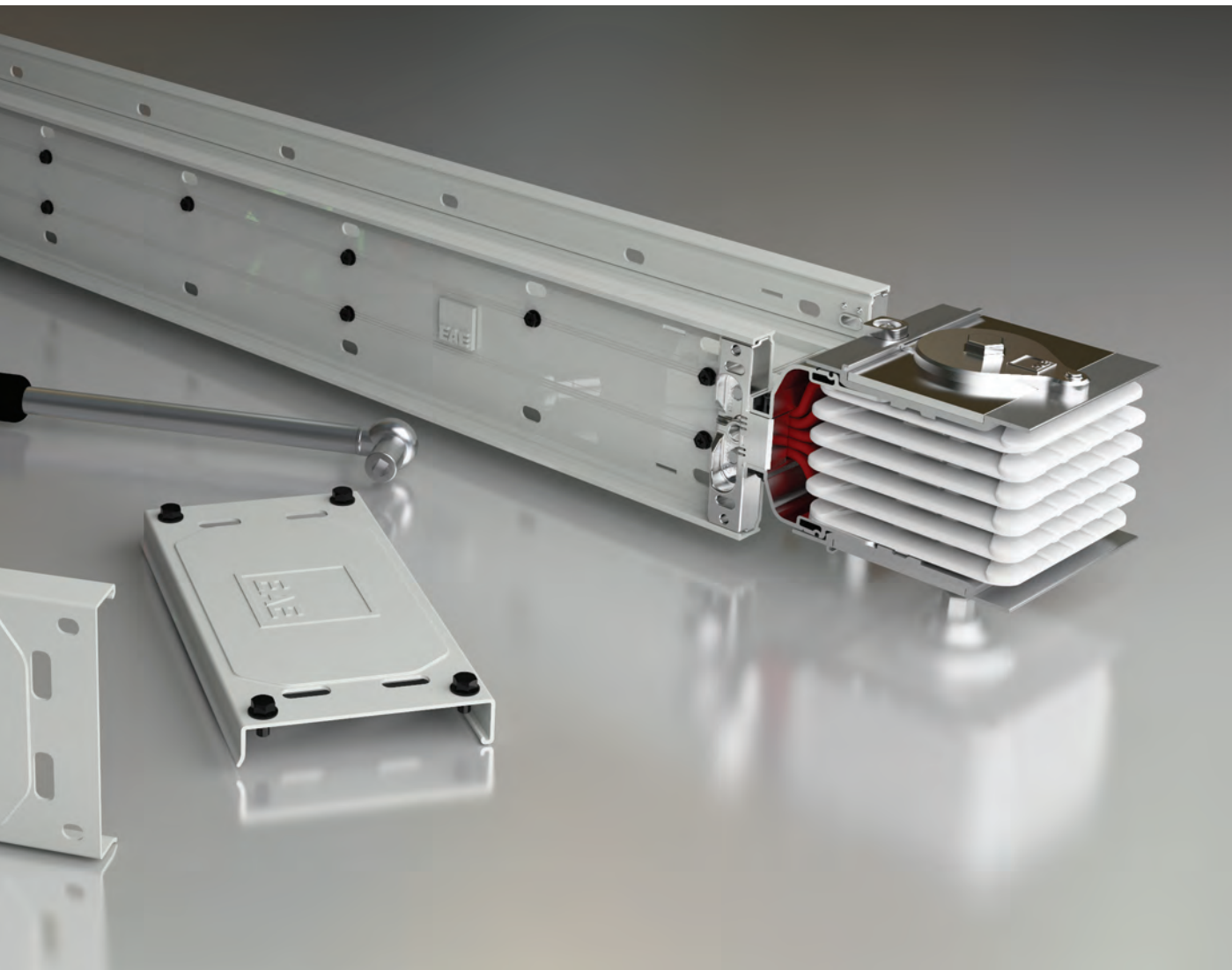

E-LINE KX-II

Busbar Systems 630...6300A



E-LINE KX-II



CONTENTS

▶▶ E-LINE KX-II

Introduction	2-3
Distribution & Horizontal Applications.....	4
Riser & Vertical Applications	5
Al Technical Characteristics.....	6-7
Cu Technical Characteristics.....	8-9
Order Code System	10
Standard Straight Length	11
Elbows.....	12-15
"T" Module	16
Reduction Modules	17
Expansions	18
Phase Transposition Module.....	19
End Closers.....	20
Panel Connections	21-25
Transformer Connections.....	26-30
Tap-off Boxes.....	31-36
Vertical and Horizontal Busbar Applications.....	37-38
Feeder Boxes	39-40
Fixing Elements.....	41-49
Joint Structure.....	50
Measuring a Special Length.....	51
Inserting "Make up Section"	52
Declaration	53
Certificate	54
Product Overview	55

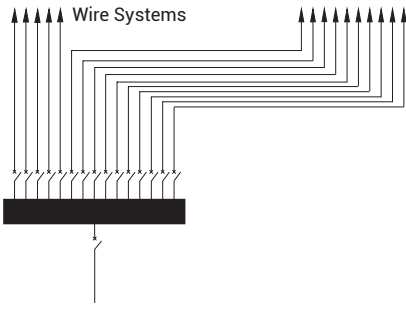

Transportation and distribution of electricity especially at high ampere ratings used to be provided by paralleling a number of large sized cables. In order to support these cables in the buildings, there were used a lot of cable trays, cable ladders, under-floor cable channels, etc. Applications of cables, such as, fixing to cable channels, branching, connecting, calculating distances between cables for heat dissipation, adjusting difference lengths, etc. need special expert workers, more time, more effort, which means more money. Even after all above difficulties and expense, the result is not efficient enough. For example, there is no flexibility in this solution.

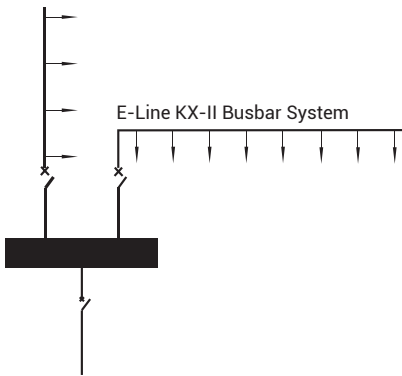

In order to eliminate all above disadvantages, modern **BUSBAR SYSTEMS** are developed. **EAE** manufactures **E-LINE** busbar systems from 25A up to 6.300A in order to convert above disadvantages to advantages. High technological, modular structured **E-LINE** busbar systems allow users to get safe energy how much and where ever they need by tap off boxes, easy and efficient planning, short installation time, better heat dissipation, automatic length adjustments, redesign / re-using capability, better electrical characteristics, etc. **E-LINE** busbar systems are designed and certified as per IEC 61439-6 standard.

Standard Prefabricated Structure

E-Line KX-II busbar system can be adapted to any kind of building structure using. Space-saving structure using. Space-saving prefabricated components. All necessary components and fitting elements are manufactured items.

** Special components can be manufactured in one week on request.*

Rapid and Efficient Installation

It has been important to keep abreast with the rapidly improving building technologies in civil engineering, the installation time was we have lowered by reducing the number of bolts on the joint points of the busbar.

Flexible Power Supply

Tap-off points at short intervals make electrical power available in all locations; the power supply can be adapted to different production processes simply by relocating the tap-off unit.

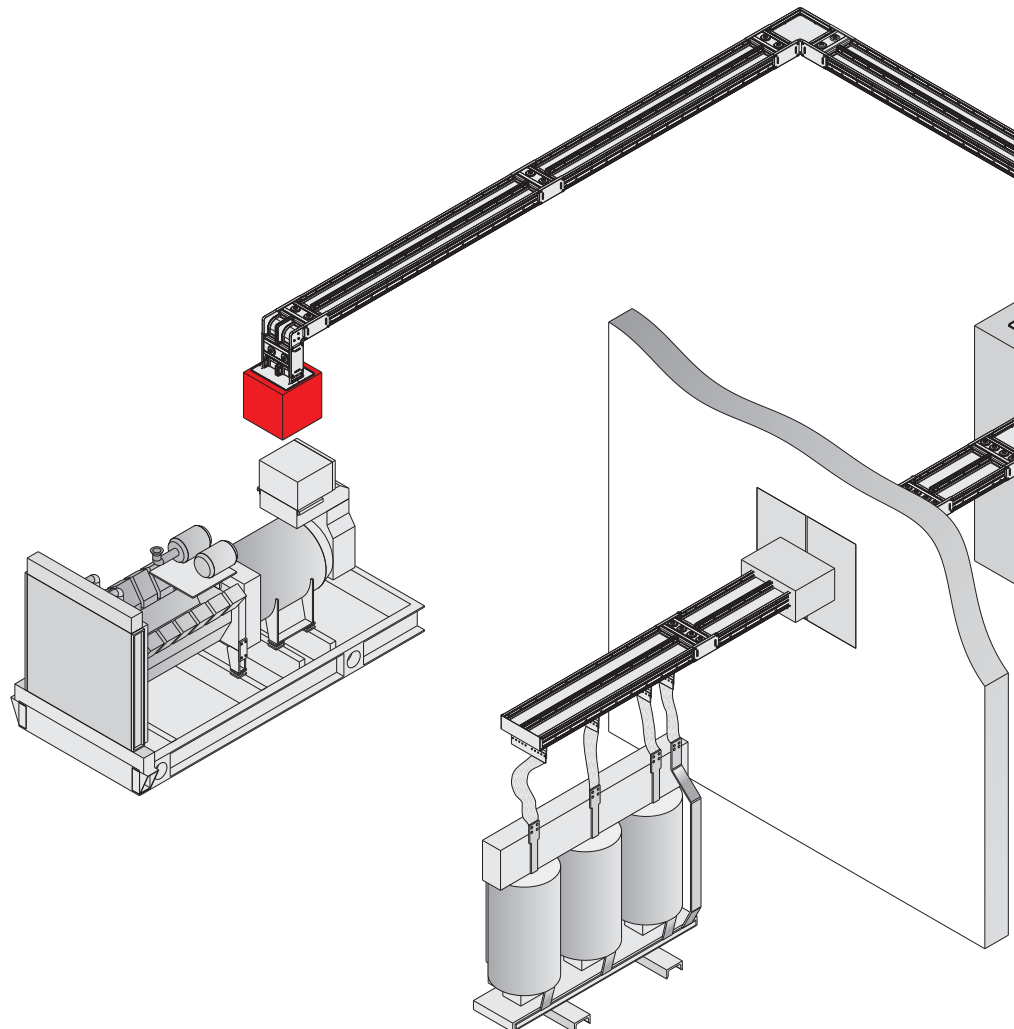

Hybrid Insulation

The perfect design for high current busbar systems is the "compact structure" where tin plated and insulated with B class polyester film and epoxy coated on conductors are tightly placed into the extruded aluminium housing (Figure 1).

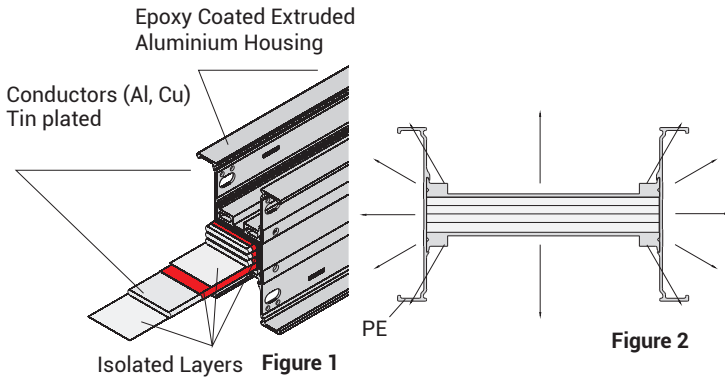

Heat Transfer

"In compact structure" there is no empty space filled with air and heat is easily transferred to the environment by the housing that works like a heat-sink (Figure 2).

Minimum Voltage Drop

In E-Line KX-II, inductive reactance is very low due to closely placed conductors. The voltage drop comparison of compact and ventilated busbar that have same cross sectional area prove the importance of the compact structure.

High Short-Circuit Endurance

As there are no support points in "compact structure" momentum levers are not formed (Figure 1). This feature ensures high short-circuit endurance (Figure 5).

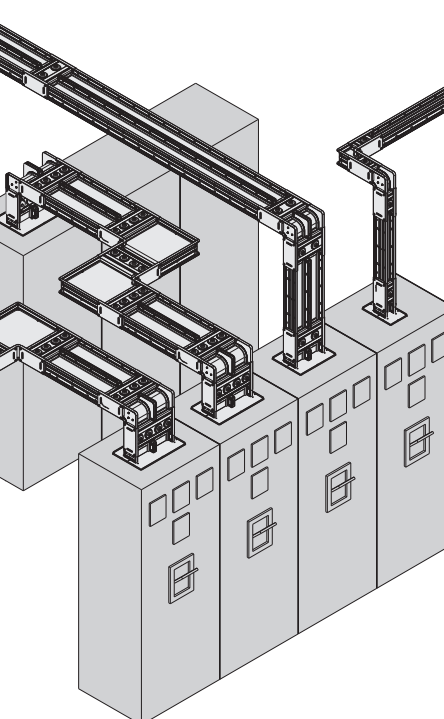
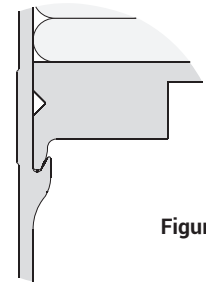

One Bolt Joint Ensures Safety and Easy Installation

E-Line KX-II Busbars are installed by tightening the "one bolt joint". Belleville spring washers on both ends of the bolt retains the original contact pressure, ensuring a more secure, reliable and maintenance-free joint.

E-Line KX-II Busbar Systems are easily installed (Figures 3-4).

*** The bolt is tightened to 83 Nm (60 lbft) using the torque spanner.**

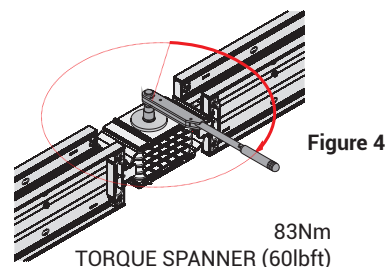
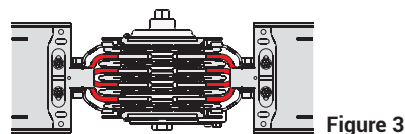

Easy and Safe Installation:

Due to alignment piece on the joint point, block joint element and busbar tray are aligned. This makes installation easier and correct on the right axes. (Figure 6).

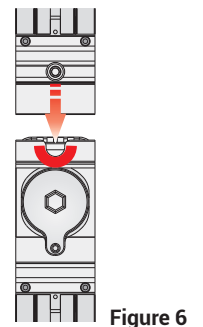

While designing an electrical distribution system with E-Line KX-II a few approximate details will be necessary.

- Location, number, type and approximate ratings of loads,
- Transformer rates and short-circuit capacities, Utilization factor= α ,
- System coordination with other distribution system (heat, water, etc),
- Determining the route of E-Line KX-II on layout, If necessary, coordination of E-Line KX-II Busbar with E-Line KO-II runs,
- Deciding on suitable hanger types.

Utilization Factor (α)

Utilization factor (α) depends on the type and number of loads.

It is usually around 0.7 or lower. The utilization factor of a line that supplies electricity to motors and lighting systems is usually lower than 0.6.

It is as low as 0.30 in weld shops of car factories, it can be 1 in lines where only one big load is supplied.

Voltage Drop

For practical voltage drop calculation, necessary values, formula and easy calculation methods are given on the technical characteristics table on pages 6-9.

Rated Current

The current is calculated using the following equation:

$$I_b = \frac{P \cdot \alpha}{\sqrt{3} \cdot U \cdot \cos \varphi}$$

I_b = Operation current (A)

P = Installed load (W)

α = Utilization factor

U = Supply voltage (V)

- Busbar current rating is chosen as equal to or higher then the calculated IB current.
- After the voltage drop calculation if the chosen current rate is not convenient, a higher rating is chosen.

Short-Circuit

Tested short-circuit capacities are given on technical characteristics table on pages 6-9.

Busbar Installation Plan

Our distributor's project & design departments will help you for preparing the installation plans on request.

Components List			
Item	Components		Quantity
1	KXC-II 20507 - STD	Busbar (20 x 3m.)	60 m.
2	KXC-II 20507 - D	Downwards Elbow	2 pcs.
3	KXC-II 20507 - R	Right Elbow	1 pc.
4	KXC-II 20507 - U	Upwards Elbow	1 pc.
5	KXC-II 20507 - L	Left Elbow	1 pc.
6	KXC-II 20507 - P11	Panel Connection	1 pc.
7	KXC-II 20507 - S10	End Closer	1 pc.
9	KXC-II 20507 - X120	Special Straight Length	1 pc.
10	KXC-II 20507 - X122	Special Straight Length	1 pc.
11	KXC-II 20507 - X200	Special Straight Length	1 pc.
12	KXC-II 20507 - X174	Special Straight Length	1 pc.
13	KXP 1650	Tap-off Box	8 pcs.
14	KXB 2550	Tap-off Box	6 pcs.

Company : Demir Makine
 Project : II.OSB Tesisleri
 Project No : 1128

Prepared by Name : Abdullah ELDELEKLİ
 Date : 02 / 01 / 2022
 Signature :

As each building's structure is different than the other for vertical applications of E-Line KX-II special projects has to be designed.

The details on this page briefly explain the necessary information for drawing a vertical application project.

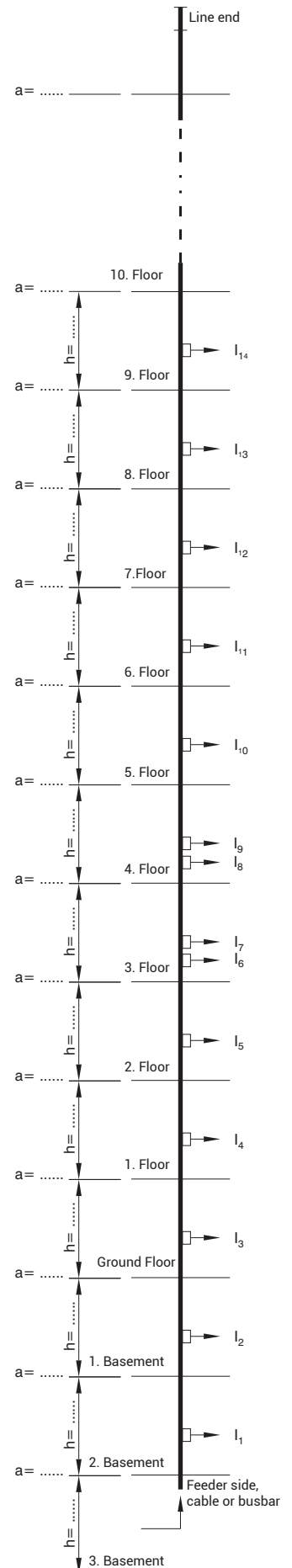
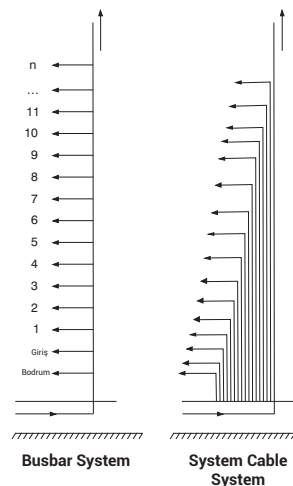
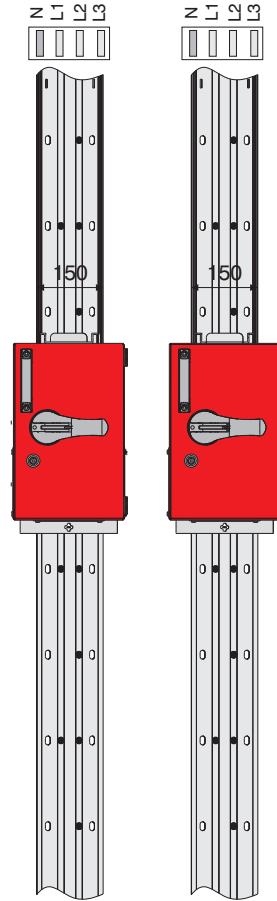
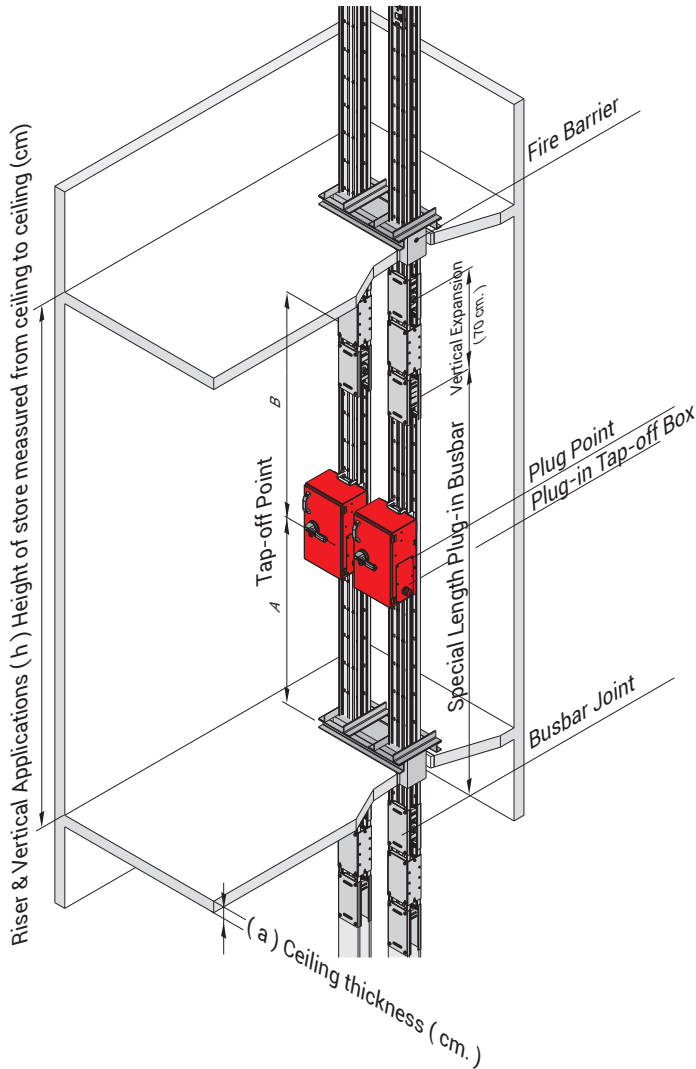

Project Design

The details below should be sent to our Project & Design department.

- Location and dimensions of the floor penetration where busbar will be installed.
- Number, height and ceiling thickness of storeys. (a=..., h=...)
- Connected load for each storey.
- Supply type of the vertical line (busbar or cable).

Please send the information to us by fax or e-mail with a sample drawing in Figure 1.

⚠ In multipath busbars in high-rise vertical shaft applications; Due to floor heights, floor thickness and product tolerances, the window or additional point alignments on the upper floors may not be the same. In order for the Tap off boxes to be aligned and the joint point not to coincide with the floor transitions, the assembly should be continued by making measurements on each floor.

■ EAE is not responsible for the potential risks that may occur in cases where the products in our catalogue are used outside of the standard phase sequences as shown in the catalogue.

Figure 1

Aluminium Conductor (Al)

Standards	IEC 61439-6, TS EN 61439-6, IEC 61439-1, TS EN 61439-1								
Rated Isolation Voltage	Ui	V	1000	at Cat IV					
Max. Rated Operational Voltage	Ue	Vac	1000						
Rated Impulse Withstand Voltage	Uimp	kV	12						
Rated Frequency	f	Hz	50						
Pollution Degree	III								
Protection Degree	IP55 / IP65								
External Mechanical Impacts (IK Code)*	Bolt-on Busbar IK10+, Plug-in Busbar IK08								
Rated Current	I_n	A	630	800	1000	1250	1600	2000	2500
Busbar Code			06	08	10	12	17	20	27
Rated Short-time Withstand Current (1s)	I _{cw}	kA	25	35	35	50	70	100	100
Rated Peak Withstand Current	I _{pk}	kA	52,5	74	74	105	154	220	220
Rated Short-time Withstand Current for PE (Housing) Conductor (1s)	I _{cw}	kA	15,0	21	21	30	42	60	60
Rated Peak Withstand Current for PE (Housing) Conductor	I _{pk}	kA	31,5	44,1	44,1	63,0	92,4	132,0	132,0
MEAN PHASE CONDUCTOR CHARACTERISTICS AT RATED CURRENT I_n									
Resistance at a conductor temperature of 20 °C	R ₂₀	mΩ/m	0,121	0,088	0,076	0,055	0,037	0,027	0,021
Average resistance at I _n , thermal balance	R	mΩ/m	0,159	0,116	0,100	0,073	0,047	0,034	0,027
Reactance (Independent from Temperature)	X	mΩ/m	0,027	0,021	0,019	0,015	0,010	0,008	0,006
Positive and negative sequence impedances at an ambient air temperature of 35 °C	Z	mΩ/m	0,161	0,118	0,102	0,075	0,048	0,035	0,028
Positive and negative sequence impedances at a conductor temperature of 20 °C	Z ₂₀	mΩ/m	0,124	0,091	0,078	0,057	0,038	0,028	0,022
DC Resistance at a conductor temperature of 20 °C for Phases and neutral	R _{ort_{ph}}	mΩ/m	0,124	0,087	0,075	0,060	0,040	0,026	0,021
DC Resistance at a conductor temperature of 20 °C for PE (Housing)	R _{PE}	mΩ/m	0,028	0,024	0,042	0,032	0,025	0,024	0,018
SECTIONS									
L1,L2,L3,N		mm ²	240	330	360	480	750	1020	1380
PE (4 ½ Conductors)		mm ²	120	165	180	240	375	510	690
PE (5 Conductors)		mm ²	240	330	360	480	750	1020	1380
Aluminium Housing Section (Aluminium)		mm ²	1686	1788	1829	1894	2128	2379	2679
Conductor Dimensions		mmxmm	6x40	6x55	6x60	6x80	6x125	6x170	6x230
Busbar Weight (4 ½ Conductors)		kg/m	8,3	9,7	10,6	12	16,3	20,8	26,9
Busbar Weight (5 Conductors)		kg/m	8,6	10,2	11,1	12,8	17,5	22,4	29,0
MEAN FAULT-LOOP CHARACTERISTICS									
Zero-sequence Impedance									
Zero-sequence impedance at a conductor temperature of 20 °C	Z _{(0)b20phN}	mΩ/m	0,572	0,419	0,355	0,265	0,176	0,134	0,102
Zero-sequence impedance at a conductor temperature of 20 °C (Housing)	Z _{(0)b20phPE}	mΩ/m	0,326	0,268	0,194	0,151	0,110	0,102	0,075
Zero-sequence impedance at an ambient temperature of 35 °C	Z _{(0)bphN}	mΩ/m	0,742	0,540	0,480	0,356	0,229	0,173	0,134
Zero-sequence impedance at an ambient temperature of 35 °C (Housing)	Z _{(0)bphPE}	mΩ/m	0,406	0,331	0,250	0,195	0,139	0,132	0,098
Resistances and Reactances									
Resistance at a conductor temperature of 20 °C	R _{b20phph}	mΩ/m	0,249	0,184	0,156	0,114	0,074	0,055	0,043
Resistance at a conductor temperature of 20 °C	R _{b20phN}	mΩ/m	0,255	0,192	0,164	0,120	0,078	0,059	0,046
Resistance at a conductor temperature of 20 °C (Housing)	R _{b20phPE}	mΩ/m	0,175	0,137	0,106	0,081	0,057	0,048	0,037
Resistance at an ambient air temperature of 35 °C	R _{bphph}	mΩ/m	0,328	0,241	0,216	0,157	0,098	0,073	0,059
Resistance at an ambient air temperature of 35 °C	R _{bphN}	mΩ/m	0,336	0,252	0,226	0,165	0,104	0,078	0,062
Resistance at an ambient air temperature of 35 °C (Housing)	R _{bphPE}	mΩ/m	0,231	0,180	0,146	0,111	0,075	0,064	0,050
Reactance (Independent from temperature)	X _{bphph}	mΩ/m	0,043	0,042	0,037	0,027	0,020	0,016	0,012
Reactance (Independent from temperature)	X _{bphN}	mΩ/m	0,075	0,058	0,051	0,039	0,028	0,022	0,017
Reactance (Independent from temperature)	X _{bphPE}	mΩ/m	0,069	0,061	0,046	0,034	0,024	0,018	0,014

Copper Conductor (Cu)

Standards	IEC 61439-6, TS EN 61439-6, IEC 61439-1, TS EN 61439-1								
Rated Isolation Voltage	U _i	V	1000	at Cat IV					
Max. Rated Operational Voltage	U _e	V _{ac}	1000						
Rated Impulse Withstand Voltage	U _{imp}	kV	12						
Rated Frequency	f	Hz	50						
Pollution Degree	III								
Protection Degree	IP55 / IP65								
External Mechanical Impacts (IK Code)*	Bolt-on Busbar IK10+, Plug-in Busbar IK08								
Rated Current	I_n	A	650	800	1000	1250	1350	1600	2000
Busbar Code			06	08	10	12	14	16	20
Rated Short-time Withstand Current (1s)	I _{cw}	kA	24	50*	50	60	75	85	100
Rated Peak Withstand Current	I _{pk}	kA	50,4	105	105	132	165	187	220
Rated Short-time Withstand Current for PE (Housing) Conductor (1s)	I _{cw}	kA	14,4	30	30	36	45	51	60
Rated Peak Withstand Current for PE (Housing) Conductor	I _{pk}	kA	28,8	63	63	75,6	94,5	112	132
MEAN PHASE CONDUCTOR CHARACTERISTICS AT RATED CURRENT I_n									
Resistance at a conductor temperature of 20 °C	R ₂₀	mΩ/m	0,113	0,093	0,061	0,051	0,040	0,034	0,025
Average resistance at I _n , thermal balance	R	mΩ/m	0,149	0,127	0,085	0,070	0,053	0,046	0,034
Reactance (Independent from Temperature)	X	mΩ/m	0,039	0,034	0,027	0,020	0,017	0,014	0,010
Positive and negative sequence impedances at an ambient air temperature of 35 °C	Z	mΩ/m	0,154	0,131	0,089	0,073	0,056	0,048	0,035
Positive and negative sequence impedances at a conductor temperature of 20 °C	Z ₂₀	mΩ/m	0,123	0,100	0,077	0,056	0,044	0,038	0,028
DC Resistance at a conductor temperature of 20 °C for Phases and neutral	R _{ort_{ph}}	W/m	0,113	0,093	0,070	0,051	0,040	0,034	0,025
DC Resistance at a conductor temperature of 20 °C for PE (Housing)	R _{PE}	mΩ/m	0,054	0,049	0,040	0,031	0,028	0,025	0,018
SECTIONS									
L1,L2,L3,N		mm ²	150	180	270	330	420	480	660
PE (4 ½ Conductors)		mm ²	75	90	135	165	210	240	330
PE (5 Conductors)		mm ²	150	180	270	330	420	480	660
Aluminium Housing Section (Aluminium)		mm ²	1449	1509	1741	1788	1842	1894	2050
Conductor Dimensions		mmxmm	6x25	6x30	6x45	6x55	6x70	6x80	6x110
Busbar Weight (4 ½ Conductors)		kg/m	11,4	12,8	17,5	19,9	23,9	26,8	35,1
Busbar Weight (5 Conductors)		kg/m	12,2	13,52	18,9	21,5	26,1	29,2	38,5
MEAN FAULT-LOOP CHARACTERISTICS									
Zero-sequence Impedance									
Zero-sequence impedance at a conductor temperature of 20 °C	Z _{(0)b20phN}	mΩ/m	0,558	0,470	0,370	0,266	0,214	0,186	0,112
Zero-sequence impedance at a conductor temperature of 20 °C (Housing)	Z _{(0)b20phPE}	mΩ/m	0,291	0,262	0,211	0,161	0,142	0,129	0,088
Zero-sequence impedance at an ambient temperature of 35 °C	Z _{(0)bphN}	mΩ/m	0,717	0,611	0,474	0,338	0,274	0,248	0,141
Zero-sequence impedance at an ambient temperature of 35 °C (Housing)	Z _{(0)bphPE}	mΩ/m	0,359	0,327	0,258	0,196	0,176	0,164	0,107
Resistances and Reactances									
Resistance at a conductor temperature of 20 °C	R _{b20phph}	mΩ/m	0,245	0,202	0,154	0,111	0,088	0,073	0,044
Resistance at a conductor temperature of 20 °C	R _{b20phN}	mΩ/m	0,255	0,211	0,163	0,119	0,094	0,079	0,048
Resistance at a conductor temperature of 20 °C (Housing)	R _{b20phPE}	mΩ/m	0,163	0,139	0,107	0,082	0,067	0,058	0,038
Resistance at an ambient air temperature of 35 °C	R _{bphph}	mΩ/m	0,324	0,270	0,203	0,146	0,117	0,102	0,057
Resistance at an ambient air temperature of 35 °C	R _{bphN}	mΩ/m	0,336	0,282	0,216	0,156	0,125	0,109	0,063
Resistance at an ambient air temperature of 35 °C (Housing)	R _{bphPE}	mΩ/m	0,215	0,186	0,142	0,108	0,090	0,081	0,050
Reactance (Independent from temperature)	X _{bphph}	mΩ/m	0,071	0,060	0,049	0,037	0,031	0,028	0,018
Reactance (Independent from temperature)	X _{bphN}	mΩ/m	0,095	0,082	0,066	0,050	0,042	0,038	0,025
Reactance (Independent from temperature)	X _{bphPE}	mΩ/m	0,077	0,068	0,056	0,034	0,036	0,033	0,021

* Duration 0,3 sec.

2250	2500	2250	2750	3000	3300	3600	4000	5000	6300
21	25	24	28	30	32	36	40	50	63
100	100	110	110	150	180	180	180	180	180
220	220	242	242	330	396	396	396	396	396
60	60	66	66	90	108	108	108	108	108
132	132	145	145	198	238	238	238	238	238
0,022	0,018	0,026	0,021	0,017	0,014	0,013	0,011	0,009	0,006
0,029	0,023	0,034	0,028	0,023	0,019	0,017	0,015	0,012	0,007
0,010	0,008	0,010	0,008	0,007	0,007	0,006	0,005	0,004	0,003
0,031	0,024	0,035	0,029	0,024	0,020	0,018	0,016	0,013	0,008
0,025	0,020	0,028	0,023	0,019	0,016	0,015	0,013	0,010	0,007
0,022	0,018	0,026	0,019	0,017	0,014	0,013	0,011	0,009	0,006
0,019	0,016	0,017	0,017	0,016	0,012	0,011	0,011	0,009	0,006
750	960	660	840	960	1140	1320	1500	1920	2880
375	480	330	420	480	570	660	750	960	1440
750	960	660	840	960	1140	1320	1500	1920	2880
2128	2314	3340	3580	3780	3845	3912	4068	4411	6725
6x125	6x160	2(6x55)	2(6x70)	2(6x80)	2(6x95)	2(6x110)	2(6x125)	2(6x160)	3(6x160)
39,7	48,9	38,9	47,8	52,9	62,2	69,5	78	97,3	146
43,8	54,1	42,4	52,0	57,9	68	76,5	85,8	107,5	161
0,120	0,100	0,135	0,106	0,093	0,080	0,070	0,063	0,048	0,033
0,093	0,074	0,085	0,070	0,064	0,060	0,050	0,047	0,037	0,026
0,158	0,129	0,175	0,140	0,118	0,103	0,089	0,081	0,061	0,041
0,120	0,095	0,106	0,089	0,079	0,075	0,063	0,059	0,047	0,033
0,049	0,039	0,056	0,044	0,038	0,031	0,028	0,024	0,019	0,013
0,053	0,043	0,060	0,047	0,041	0,034	0,030	0,027	0,021	0,014
0,043	0,035	0,041	0,034	0,031	0,026	0,023	0,021	0,017	0,012
0,067	0,053	0,075	0,061	0,050	0,041	0,037	0,032	0,025	0,017
0,073	0,058	0,080	0,065	0,054	0,046	0,040	0,036	0,028	0,018
0,058	0,047	0,055	0,047	0,040	0,036	0,031	0,029	0,023	0,016
0,020	0,015	0,018	0,016	0,014	0,013	0,010	0,010	0,007	0,005
0,027	0,022	0,025	0,021	0,019	0,018	0,015	0,014	0,011	0,007
0,023	0,018	0,022	0,018	0,017	0,015	0,012	0,011	0,009	0,006

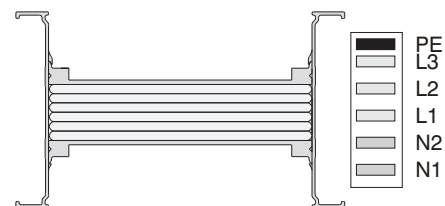

Voltage Drop Calculation

Generally Voltage drop of a busbar system can be calculated with the following formula.

$$\Delta U = \sqrt{3} \cdot L \cdot I \cdot (R \cdot \cos\phi + X \cdot \sin\phi) \cdot 10^{-3} \text{ [V]}$$

- ΔU = Voltage Drop (V)
- L = Line Length (m)
- I = Line Current or Load (A)
- R = Resistance (mW/m)
- X = Reactance (mW/m)

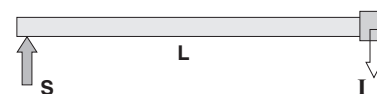

S = Supply Point

- All phase conductor characteristics had been determined according to Annex BB of IEC / EN 61439-6.
- Fault-loop zero-sequences impedances had been determined according to Annex CC of IEC / EN 61439-6.
- Fault-loop resistances and impedances had been determined according to Annex DD of IEC / EN 61439-6.
- * IK10 corresponds to impact energy of 20J according to IEC 62262.

BUSBAR TYPE
 CONDUCTOR MATERIAL
 BUSBAR CODE
 PROTECTION DEGREE
 CONDUCTOR CONFIGURATION
 UTILIZATION TYPE P - Plug-in / B - Bolt-on
 COMPONENT

KX A-II 17 5 07 - B - TR41

Busbar Type

Aluminium (Al) **A-II** CONDUCTOR MATERIAL
 Copper (Cu) **C-II**

KXA-II Al Conductor		KXC-II Cu Conductor		Conductor Size
Rated Current	Busbar Code	Rated Current	Busbar Code	
-	-	*650	06	6x25
-	-	*800	08	6x30
*630	06	-	-	6x40
-	-	*1000	10	6x45
800	08	1250	12	6x55
1000	10	-	-	6x60
-	-	1350	14	6x70
1250	12	1600	16	6x80
-	-	2000	20	6x110
1600	17	2250	21	6x125
-	-	2500	25	6x160
2000	20	-	-	6x170
2500	27	-	-	6x230
-	-	2250	24	2(6x55)
-	-	2750	28	2(6x70)
2350	21	3000	30	2(6x80)
2500	25	3300	32	2(6x95)
-	-	3600	36	2(6x110)
3000	32	4000	40	2(6x125)
3300	33	-	-	2(6x140)
-	-	5000	50	2(6x160)
4000	40	-	-	2(6x170)
5000	51	-	-	2(6x250)
-	-	6300	63	3(6x160)
6300	63	-	-	3(6x200)

(*)Bolt-on tap-off box can not be used on the joints of mentioned ratings of busbars. Plug-in points can be at one side only

BUSBAR CODE

IP55 / IP65* **5** PROTECTION DEGREE

*Please call us for IP65 orders.
 IP65 are not recommended for outdoor applications.
 Please check CR and CCR catalog.

Number of Conductors	Code	Conductor Configuration									
		L1	L2	L3	N1	N2	PE	½ PE	CPE	½ CPE	PE (Housing)
4 ½ Conductors	07	✓	✓	✓	✓	/	/	✓	/	/	✓
4 ½ Conductors	08	✓	✓	✓	✓	/	/	/	/	✓	✓
5 Conductors	05	✓	✓	✓	✓	/	/	✓	/	/	✓
5 Conductors	09	✓	✓	✓	✓	/	/	/	✓	/	✓
6 Conductors	06	✓	✓	✓	✓	✓	/	✓	✓	✓	✓

COMPONENTS

Standard Length.....	STD
Special Length.....	X
Upwards Elbow.....	U
Downwards Elbow.....	D
Right Elbow.....	R
Left Elbow.....	L
Left Horizontal Offset.....	LH
Right Horizontal Offset.....	RH
Upwards Vertical Offset.....	UV
Downwards Vertical Offset.....	DV
Upwards Left Combined Offset.....	KUL
Upwards Right Combined Offset.....	KUR
Downwards Left Combined Offset.....	KDL
Downwards Right Combined Offset.....	KDR
Left Upwards Combined Offset.....	KLU
Right Upwards Combined Offset.....	KRU
Left Downwards Combined Offset.....	KLD
Right Downwards Combined Offset.....	KRD
End Closer.....	S
Reduction.....	RD
Left Side Feeder "T".....	TYL
Right Side Feeder "T".....	TYR
Central Feeder "T".....	TO
Horizontal Expansion.....	YDT
Vertical Expansion.....	DDT
Phase Transposition Module.....	FDM
Panel Connection.....	P10
Panel Connection.....	P11
Upwards Panel Connection.....	PU20
Upwards Panel Connection.....	PU21
Downwards Panel Connection.....	PD20
Downwards Panel Connection.....	PD21
Right Panel Connection.....	PR30
Right Panel Connection.....	PR31
Left Panel Connection.....	PL30
Left Panel Connection.....	PL31
Panel Connection.....	P40
Panel Connection.....	P41
Transformer Connection.....	TR11
Upwards Transformer Con.....	TU21
Downwards Transformer Con.....	TD21
Transformer Connection.....	TR31
Transformer Connection.....	TR41
Right Transformer Connection.....	TR51
Left Transformer Connection.....	TL51
Transformer Connection.....	TR61
Transformer Connection.....	TR71
Feeder Box.....	B10
Feeder Box.....	B11
Central Feeder Box.....	BO
Flexible.....	F

*TYPE	Utilization Type
(B) Bolt-on	Energy is supplied from the joints.
(P) Plug-in	Energy is supplied from the joints and the plug-in points.

ELINEKX-II

►► Standard Straight Length

- BUSBAR TYPE
- CONDUCTOR MATERIAL
- BUSBAR CODE
- PROTECTION DEGREE
- CONDUCTOR CONFIGURATION
- UTILIZATION TYPE P - Plug-in / B - Bolt-on
- COMPONENT

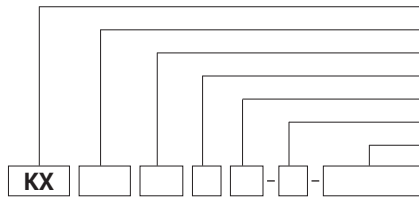

Bolt-on

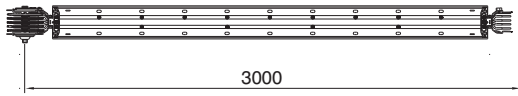

Electrical energy up to 1000 A can be supplied from the joints of bolt-on type by bolt-on tap-off boxes

Note:

3000 Busbar energy should be turned off, before installing bolt-on type tap-off boxes.

Plug-in

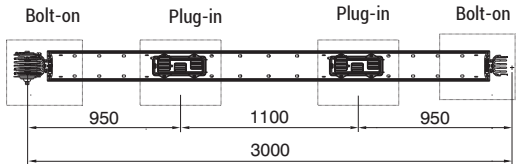

Electrical energy up to 1000 A can be supplied from the joints and up to 630 A can be supplied from the plug

Table For Outer Dimension of Busbars

KXA-II Al Conductor		KXC-II Cu Conductor		A (mm)
Rated Current	Busbar Code	Rated Current	Busbar Code	
-	-	*650	06	77,5
-	-	*800	08	82,5
*630	06	-	-	91
-	-	*1000	10	96
800	08	1250	12	106
1000	10	-	-	111
-	-	1350	14	121
1250	12	1600	16	131
-	-	2000	20	161
1600	17	2250	21	176
-	-	2500	25	211
2000	20	-	-	221
2500	27	-	-	281
-	-	2250	24	202
-	-	2750	28	232
2350	21	3000	30	252
2500	25	3300	32	282
-	-	3600	36	312
3000	32	4000	40	342
3300	33	-	-	372
-	-	5000	50	412
4000	40	-	-	432
5000	51	-	-	592
-	-	6300	63	612
6300	63	-	-	732

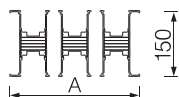
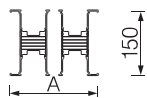
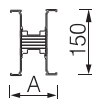

Bolt-on Standard Straight Length Busbar - S T D

Sample Order:
2500 A, Copper, Bolt-on, IP 55, 4 ½ conductors

KXC-II 25507 - B - STD

Plug-in Standard Straight Length Busbar - S T D

Sample Order:
1250 A, Copper, Plug-in, IP 55, 4 ½ conductors

KXC-II 12507 - P - STD

Note:

Please, determine number and side of plug-in points (single or double side).

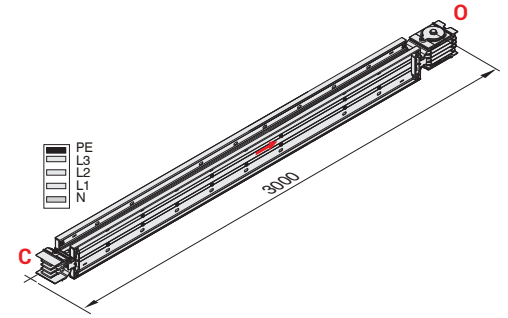

Applications:

- As feeder or sub-feeder line,
- Where a load has to be supplied from the busbar.

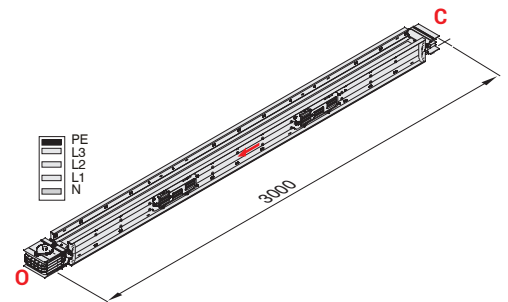

Applications:

- In application of bolt-on
- As vertical feeder line high rise buildings
- For frequent energy supply
- If continuous energy needed, while tap-offs installed.

Special Straight Length

Special Straight Length in (cm)

Sample Order:
2500 A, Copper, Bolt-on, IP 55, 4 ½ conductors, 147cm

KXC-II 25507 - B - X - 147

Note:

Bolt-on Minimum Length = 35 cm
Plug-in Minimum Length = 100 cm

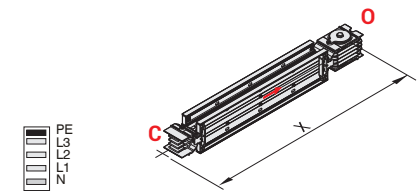

Important Notice for the Tap-off box use;

*It is not possible to install tap-off box at joint side for KXA-II 630A,800A,KXC-II 650A, 800A,1000A and 1250A. KXA-II 630A,800A,KXC-II 650A,800A,1000A and 1250A busbar range may have plug-in windows at one side only. It is highly recommended to consider these points in your project designs.

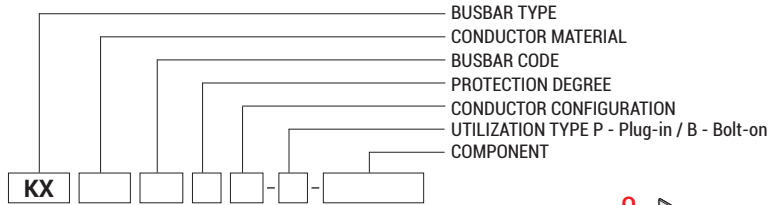

Upwards Elbow - U

Sample Order:
3300 A, Copper, Bolt-on,
IP 55, 4 ½ conductors

KXC-II 32507 - B - U

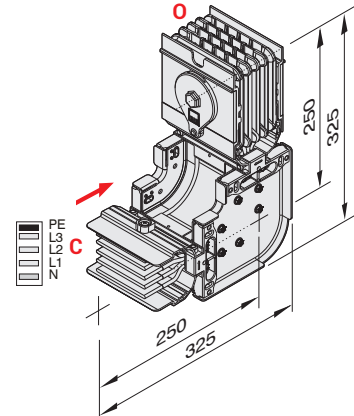

Downwards Elbow - D

Sample Order:
3300 A, Copper, Bolt-on,
IP 55, 4 ½ conductors

KXC-II 32507 - B - D

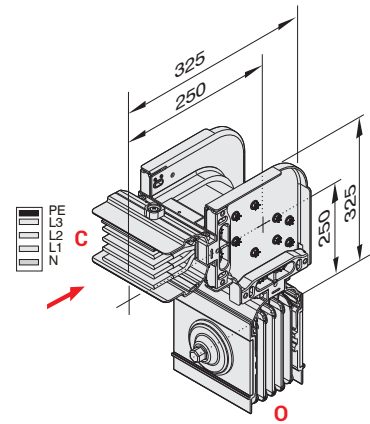

KXA-II Al Conductor		KXC-II Cu Conductor		A	B
Rated Current	Busbar Code	Rated Current	Busbar Code	(mm)	(mm)
-	-	*650	06	252	214
-	-	*800	08	257	216
*630	06	-	-	267	222
-	-	*1000	10	272	224
800	08	1250	12	282	229
1000	10	-	-	287	232
-	-	1350	14	297	236
1250	12	1600	16	307	241
-	-	2000	20	337	256
1600	17	2250	21	352	264
-	-	2500	25	387	281
2000	20	-	-	397	286
2500	27	-	-	457	316
-	-	2250	24	377	276
-	-	2750	28	407	291
2350	21	3000	30	427	301
2500	25	3300	32	457	316
-	-	3600	36	487	331
3000	32	4000	40	517	346
3300	33	-	-	547	361
-	-	5000	50	587	381
4000	40	-	-	607	391
5000	51	-	-	767	471
-	-	6300	63	787	481
6300	63	-	-	907	541

Left Elbow - L

Sample Order:
2000 A, Copper, Bolt-on,
IP 55, 4 ½ conductors

KXC-II 20507 - B - L

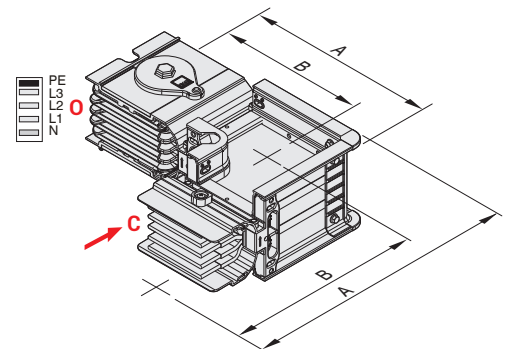

Right Elbow - R

Sample Order:
2000 A, Copper, Bolt-on,
IP 55, 4 ½ conductors

KXC-II 20507 - B - R

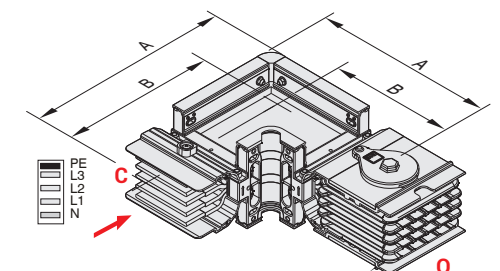

■ Special left or right elbows between 90° and 180° can be manufactured upon request.
■ The dimensions given above are minimum values. ■ Please call us for non-standard components.

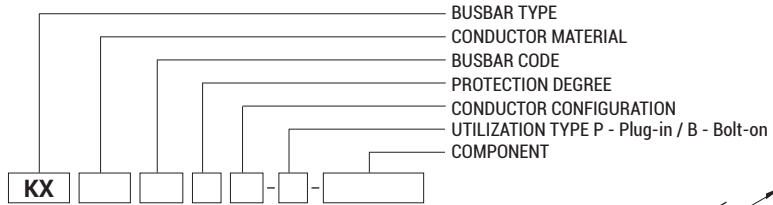

Upwards Vertical Offset - U

Sample Order:
H=25 cm, 2000 A, Copper Bolt-on,
IP 55, 4 ½ conductors

KXC-II 20507-B-UV25

Note:
H=min:25 cm max:49 cm

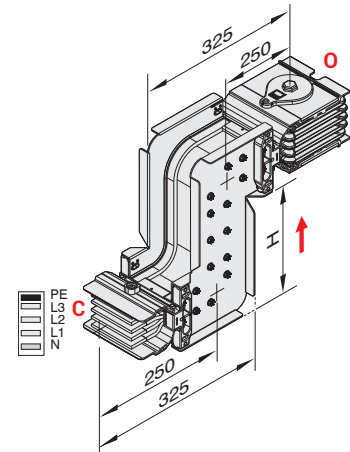

Downwards Vertical Offset - D

Sample Order:
H=25 cm, 2000 A, Copper Bolt-on,
IP 55, 4 ½ conductors

KXC-II 20507-B-DV25

Note:
H=min:25 cm max:49 cm

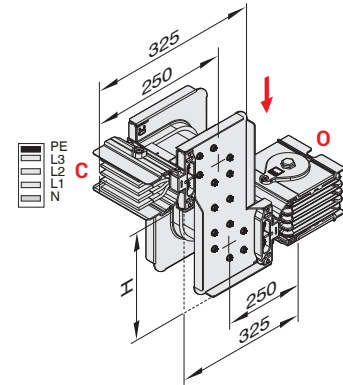

KXA-II Al Conductor		KXC-II Cu Conductor		A	B	H _{max}
Rated Current	Busbar Code	Rated Current	Busbar Code	(mm)	(mm)	(mm)
-	-	*650	06	252	214	427
-	-	*800	08	257	216	432
*630	06	-	-	267	222	442
-	-	*1000	10	272	224	447
800	08	1250	12	282	229	457
1000	10	-	-	287	232	462
-	-	1350	14	297	236	472
1250	12	1600	16	307	241	482
-	-	2000	20	337	256	512
1600	17	2250	21	352	264	527
-	-	2500	25	387	281	562
2000	20	-	-	397	286	572
2500	27	-	-	457	316	632
-	-	2250	24	377	276	552
-	-	2750	28	407	291	582
2350	21	3000	30	427	301	602
2500	25	3300	32	457	316	632
-	-	3600	36	487	331	662
3000	32	4000	40	517	346	692
3300	33	-	-	547	361	722
-	-	5000	50	587	381	762
4000	40	-	-	607	391	782
5000	51	-	-	767	471	942
-	-	6300	63	787	481	962
6300	63	-	-	907	541	1082

Left Horizontal Offset - L

Sample Order:
H=60 cm, 3300 A, Copper, Bolt-on,
IP 55, 4 ½ conductors

KXC-II 32507-B-LH60

Note:
H=min:28 cm,
max: *Please see table.
Used, if two horizontal elbows
can not fit.

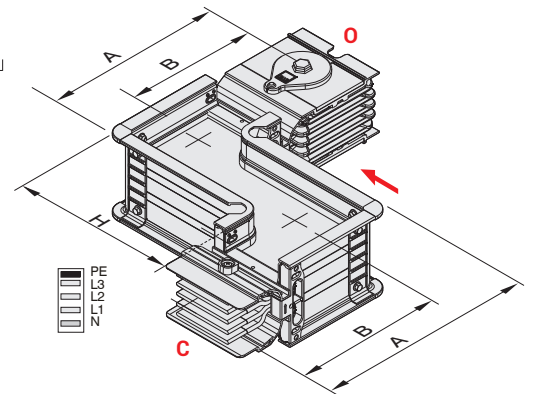

Right Horizontal Offset - R

Sample Order:
H=60 cm, 3300 A, Copper, Bolt-on,
IP 55, 4 ½ conductors

KXC-II 32507-B-RH60

Note:
H=min:28 cm,
max: *Please see table.
Used, if two horizontal elbows can not fit.

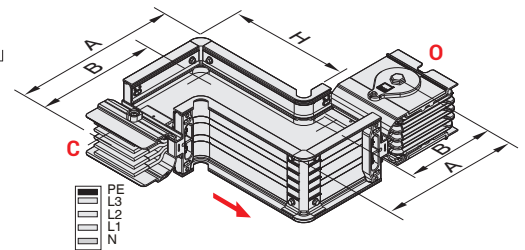

■ Special left or right elbows between 90° and 180° can be manufactured upon request.
■ The dimensions given above are minimum values. ■ Please call us for non-standard components.

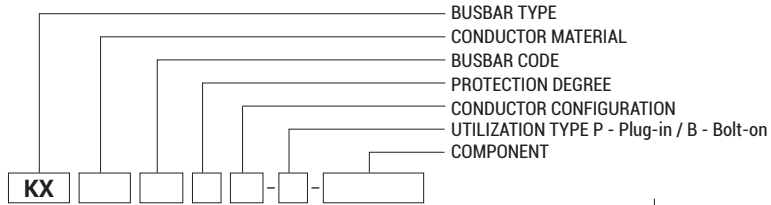

KXA-II Al Conductor		KXC-II Cu Conductor		A	B
Rated Current	Busbar Code	Rated Current	Busbar Code	(mm)	(mm)
-	-	*650	06	252	214
-	-	*800	08	257	216
*630	06	-	-	267	222
-	-	*1000	10	272	224
800	08	1250	12	282	229
1000	10	-	-	287	232
-	-	1350	14	297	236
1250	12	1600	16	307	241
-	-	2000	20	337	256
1600	17	2250	21	352	264
-	-	2500	25	387	281
2000	20	-	-	397	286
2500	27	-	-	457	316
-	-	2250	24	377	276
-	-	2750	28	407	291
2350	21	3000	30	427	301
2500	25	3300	32	457	316
-	-	3600	36	487	331
3000	32	4000	40	517	346
3300	33	-	-	547	361
-	-	5000	50	587	381
4000	40	-	-	607	391
5000	51	-	-	767	471
-	-	6300	63	787	481
6300	63	-	-	907	541

Upwards Left Combined Offset - K U L

Sample Order:
3300 A, Copper, Bolt-on,
IP 55, 4 ½ conductors

KXC-II 32507 - B - KUL

Note:
H=min. 30 cm

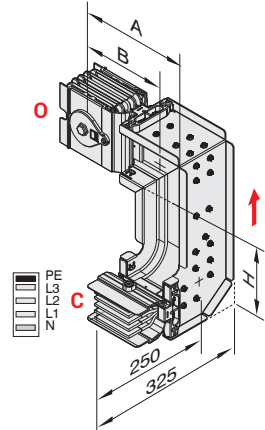

Upwards Right Combined Offset - K U R

Sample Order:
3300 A, Copper, Bolt-on,
IP 55, 4 ½ conductors

KXC-II 32507 - B - KUR

Note:
H=min. 30 cm

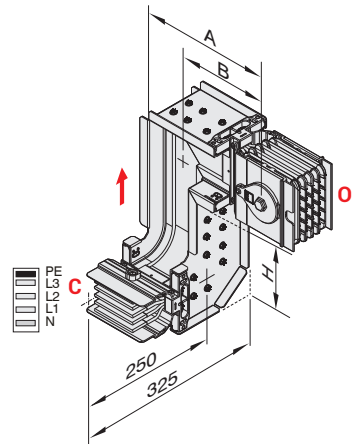

Downwards Left Combined Offset - K D L

Sample Order:
3300 A, Copper, Bolt-on,
IP 55, 4 ½ conductors

KXC-II 32507 - B - KDL

Note:
H=min. 30 cm

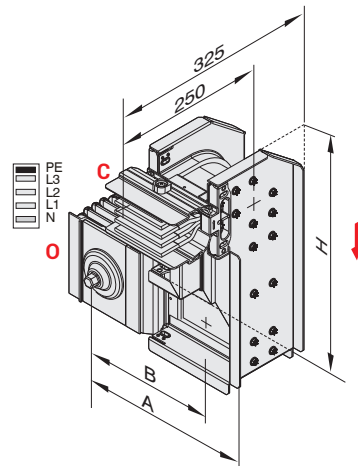

Downwards Right Combined Offset - K D R

Sample Order:
3300 A, Copper, Bolt-on,
IP 55, 4 ½ conductors

KXC-II 32507 - B - KDR

Note:
H=min. 30 cm

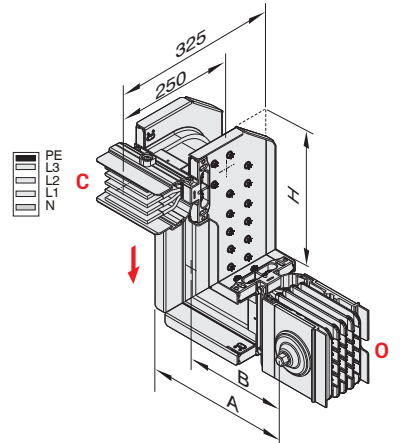

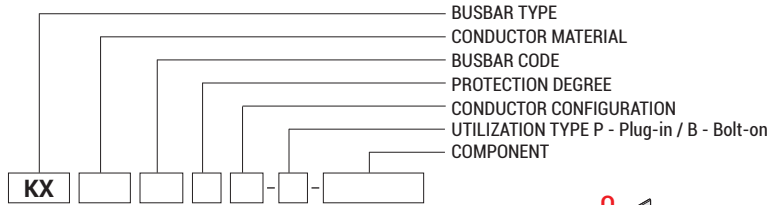

Left Upwards Combined Offset - K L U

Sample Order:
3300 A, Copper, Bolt-on,
IP 55, 4 conductors

KXC-II 32507 - B - KLU

Note
H=min. 30 cm

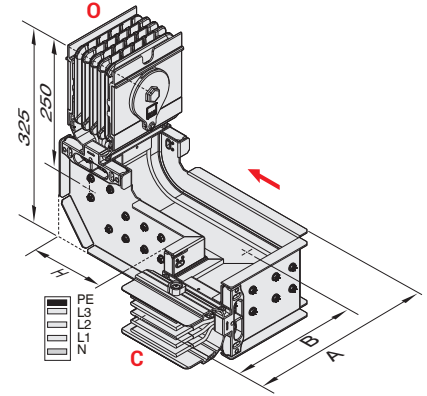

Right Upwards Combined Offset - K R U

Sample Order:
3300 A, Copper, Bolt-on,
IP 55, 4 conductors

KXC-II 32507 - B - KRU

Note
H=min. 30 cm

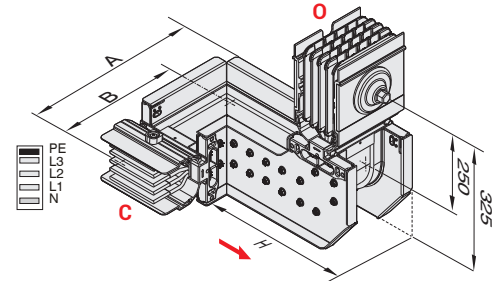

Left Downwards Combined Offset - K L D

Sample Order:
3200 A, Copper, Bolt-on,
IP 55, 4 conductors

KXC-II 32507 - B - KLD

Note
H=min. 30 cm

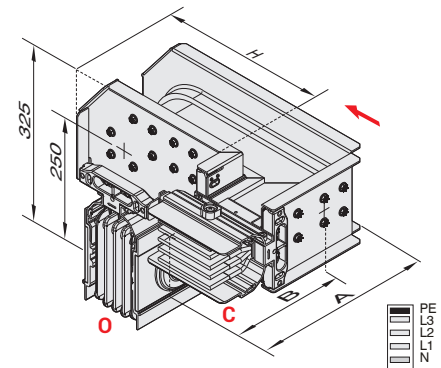

Right Downwards Combined Offset - K R D

Sample Order:
3300 A, Copper, Bolt-on,
IP 55, 4 conductors

KXC-II 32507 - B - KR D

Note
H=min. 30 cm

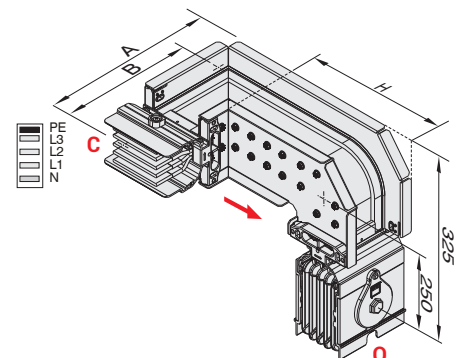

KXA-II Al Conductor		KXC-II Cu Conductor		A	B
Rated Current	Busbar Code	Rated Current	Busbar Code	(mm)	(mm)
-	-	*650	06	252	214
-	-	*800	08	257	216
*630	06	-	-	267	222
-	-	*1000	10	272	224
800	08	1250	12	282	229
1000	10	-	-	287	232
-	-	1350	14	297	236
1250	12	1600	16	307	241
-	-	2000	20	337	256
1600	17	2250	21	352	264
-	-	2500	25	387	281
2000	20	-	-	397	286
2500	27	-	-	457	316
-	-	2250	24	377	276
-	-	2750	28	407	291
2350	21	3000	30	427	301
2500	25	3300	32	457	316
-	-	3600	36	487	331
3000	32	4000	40	517	346
3300	33	-	-	547	361
-	-	5000	50	587	381
4000	40	-	-	607	391
5000	51	-	-	767	471
-	-	6300	63	787	481
6300	63	-	-	907	541

ELINEKX-II

►► "T" Module

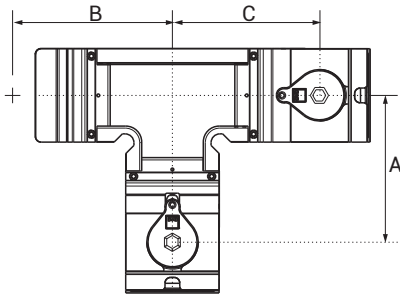
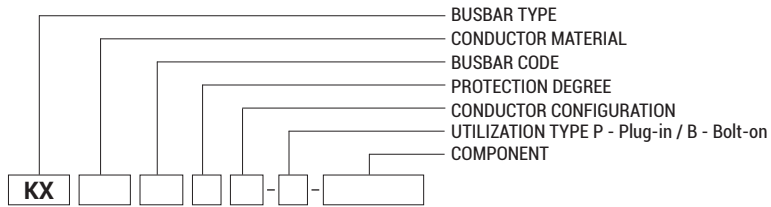

Right Side Feeder "T" - T Y R

Sample Order:
2500 A, Copper, Bolt-on,
IP 55, 4 ½ conductors

KXC-II 25507 - B - TYR

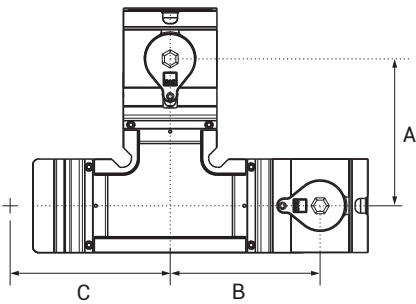
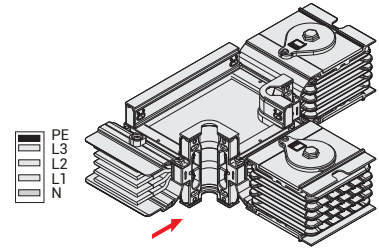

Right Side Feeder "T" - T Y L

Sample Order:
2500 A, Copper, Bolt-on,
IP 55, 4 conductors

KXA-II 25504 - B - TYL

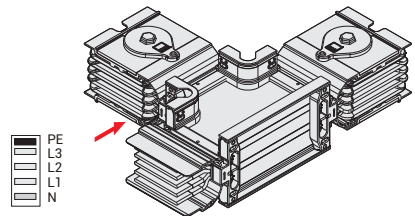

KXA-II Al Conductors		KXC-II Cu Conductors		A	B	C
Rated Current	Busbar Code	Rated Current	Busbar Code	(mm)	(mm)	(mm)
-	-	*650	06	214	214	214
-	-	*800	08	216	216	216
*630	06	-	-	222	222	222
-	-	*1000	10	224	224	224
800	08	1250	12	229	229	229
1000	10	-	-	232	232	232
-	-	1350	14	236	236	236
1250	12	1600	16	241	241	241
-	-	2000	20	256	256	256
1600	17	2250	21	264	264	264
-	-	2500	25	281	281	281
2000	20	-	-	286	286	286
2500	27	-	-	316	316	316
-	-	2250	24	276	276	276
-	-	2750	28	291	291	291
2350	21	3000	30	301	301	301
2500	25	3300	32	316	316	316
-	-	3600	36	331	331	331
3000	32	4000	40	346	346	346
3300	33	-	-	361	361	361
-	-	5000	50	381	381	381
4000	40	-	-	391	391	391
5000	51	-	-	471	471	471
-	-	6300	63	481	481	481
6300	63	-	-	541	541	541

Central Feeder "T" - T O

Sample Order:
3300 A, Bolton, Copper
IP 55, 4 ½ conductors

KXC-II 32507 - B - TO

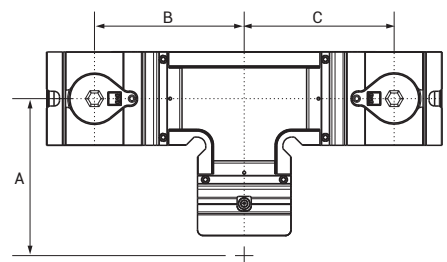
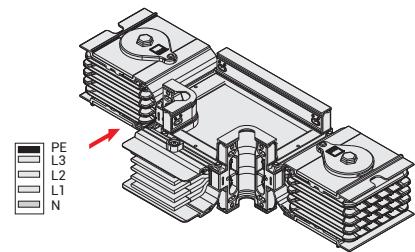

ELINEKX-II

►► Reduction Modules

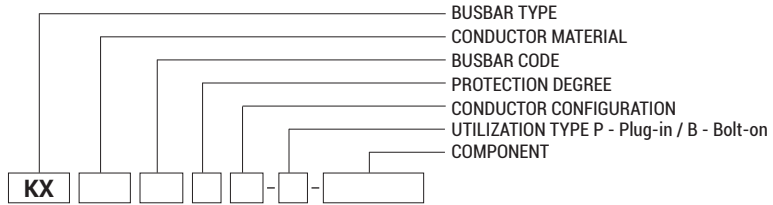

Reduction

Is used to change the busbar cross section.

NOTE:

Decisions and selection of reduction module and protection on lower side is under the customer's responsibility.

Reduction

- R D

Reduced Busbar Current

Sample Order:
2000A / 1600A, Copper, Bolt-on,
IP 55, 4 ½ conductors

KXC-II 20507 - B - RD16

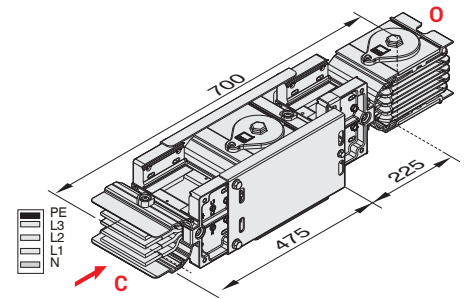

Reducers Table

KXA-II Al Conductor		Reduced Busbar Current												
Rated Current		06	08	10	12	17	20	27	21	25	32	33	40	51
800	08	✓	-	-	-	-	-	-	-	-	-	-	-	-
1000	10	✓	✓	-	-	-	-	-	-	-	-	-	-	-
1250	12	-	✓	✓	-	-	-	-	-	-	-	-	-	-
1600	17	-	-	✓	✓	-	-	-	-	-	-	-	-	-
2000	20	-	-	-	✓	✓	-	-	-	-	-	-	-	-
2500	27	-	-	-	-	✓	-	✓	-	-	-	-	-	-
2350	21	-	-	-	-	✓	✓	-	-	-	-	-	-	-
2500	25	-	-	-	-	-	✓	✓	-	-	-	-	-	-
3000	32	-	-	-	-	-	-	✓	✓	✓	-	-	-	-
3300	33	-	-	-	-	-	-	✓	-	✓	✓	-	-	-
4000	40	-	-	-	-	-	-	-	-	-	✓	✓	-	-
5000	51	-	-	-	-	-	-	-	-	-	-	✓	✓	-
6300	63	-	-	-	-	-	-	-	-	-	-	-	✓	✓

KXC-II Cu Conductor		Reduced Busbar Current															
Rated Current		06	08	10	12	14	16	20	21	25	24	28	30	32	36	40	50
800	08	✓	-	-	-	-	-	-	-	-	-	-	-	-	-	-	-
1000	10	✓	✓	-	-	-	-	-	-	-	-	-	-	-	-	-	-
1250	12	-	✓	✓	-	-	-	-	-	-	-	-	-	-	-	-	-
1350	14	-	-	✓	✓	-	-	-	-	-	-	-	-	-	-	-	-
1600	16	-	-	-	✓	✓	-	-	-	-	-	-	-	-	-	-	-
2000	20	-	-	-	-	✓	✓	-	-	-	-	-	-	-	-	-	-
2250	21	-	-	-	-	-	✓	✓	-	-	-	-	-	-	-	-	-
2500	25	-	-	-	-	-	-	✓	✓	-	✓	-	-	-	-	-	-
2250	24	-	-	-	-	-	✓	✓	-	-	-	-	-	-	-	-	-
2750	28	-	-	-	-	-	-	-	✓	✓	✓	-	-	-	-	-	-
3000	30	-	-	-	-	-	-	-	-	✓	-	✓	-	-	-	-	-
3300	32	-	-	-	-	-	-	-	-	-	-	✓	✓	-	-	-	-
3600	36	-	-	-	-	-	-	-	-	-	-	-	✓	✓	-	-	-
4000	40	-	-	-	-	-	-	-	-	-	-	-	-	-	✓	✓	-
5000	50	-	-	-	-	-	-	-	-	-	-	-	-	-	-	✓	✓
6300	63	-	-	-	-	-	-	-	-	-	-	-	-	-	-	✓	✓

■ Please call us for non-standard components. ■ The dimensions given above are minimum values.

BUSBAR TYPE
 CONDUCTOR MATERIAL
 BUSBAR CODE
 PROTECTION DEGREE
 CONDUCTOR CONFIGURATION
 UTILIZATION TYPE P - Plug-in / B - Bolt-on
 COMPONENT

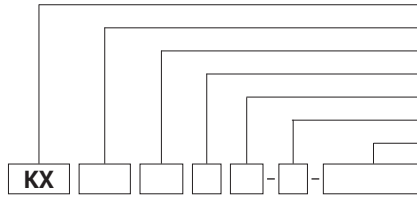

Vertical Expansion

Used for vertical applications in multi storey buildings.

One vertical expansion unit is advised to be used at every floor between fixed support points.

Vertical Expansion - D D T

Sample Order:
 2000 A, Copper, Bolt-on,
 IP 55, 4 conductors

KXC-II 20507 - B - DDT

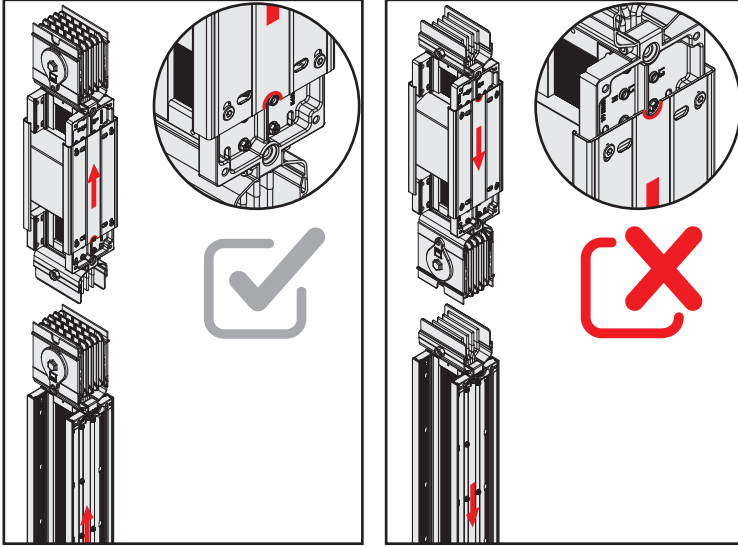
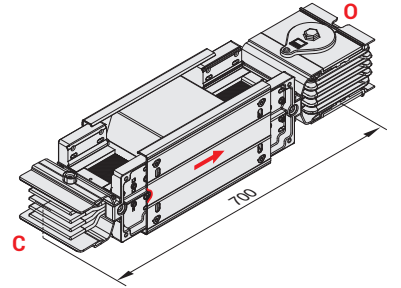

Horizontal Expansion

Used at every 40m in long horizontal straight lines and building expansion points.

Note:

- 1) Horizontal expansion joint should be utilised if busbar line is crossing to adjacent through building expansion joints.
- 2) This module is used on the long busbar line (>75m.) where line is ended by end closure and is not fixed on the support rigidly.
- 3) Horizontal expansion joint has sufficient movement span of 54mm.

EAE requests to be consulted during design stage.

Horizontal Expansion - Y D T

Sample Order:
 2500 A, Copper, Bolt-on,
 IP 55, 4 conductors

KXC-II 25507 - B - YDT

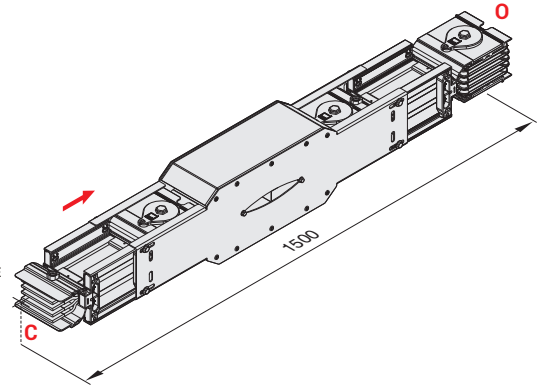

Attention!

The total length of the module should be adjusted to 1500 mm. after installation.

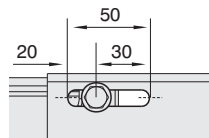
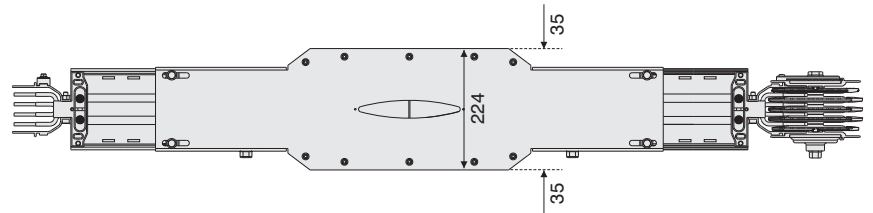

17mm ←→ 27mm

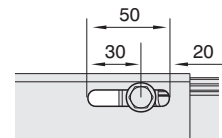

27mm ←→ 17mm

ELINEKX-II

►► Phase Transposition Module

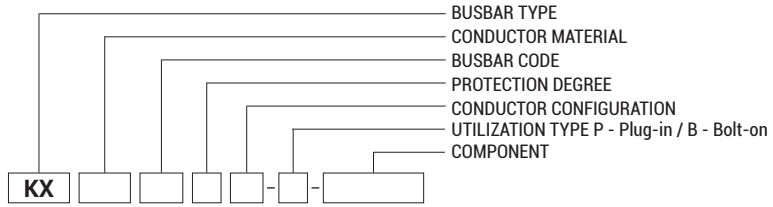

Phase Transposition Module

They used for transposition of phase sequence

Phase Transposition - F D M Module

Sample Order:
2500 A, Copper, Bolt-on,
IP 55, 4 ½ conductors

KXC-II 25507 - B - FDM

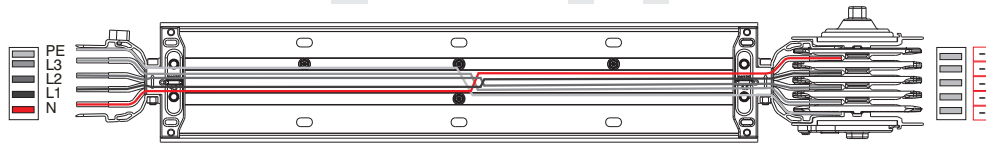
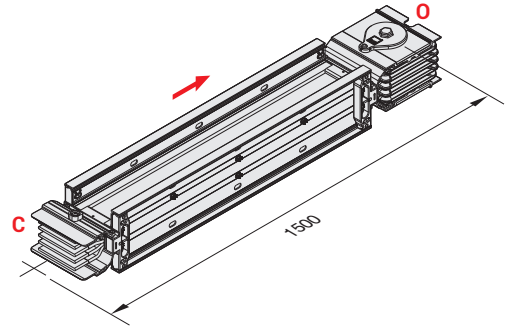

After the Phase Transposition Module; when the Tap-Off boxes needed to be installed. An approval from the customer representative is required.

FDM Dimension Table

KXA-II Al Conductor		KXC-II Cu Conductor		A (mm)
Rated Currents	Busbar Code	Rated Currents	Busbar Code	
-	-	*650	06	77,5
-	-	*800	08	82,5
*630	06	-	-	91
-	-	*1000	10	96
800	08	1250	12	106
1000	10	-	-	111
-	-	1350	14	121
1250	12	1600	16	131
-	-	2000	20	161
1600	17	2250	21	176
-	-	2500	25	211
2000	20	-	-	221
2500	27	-	-	281
-	-	2250	24	202
-	-	2750	28	232
2350	21	3000	30	252
2500	25	3300	32	282
-	-	3600	36	312
3000	32	4000	40	342
3300	33	-	-	372
-	-	5000	50	412
4000	40	-	-	432
5000	51	-	-	592
-	-	6300	63	612
6300	63	-	-	732

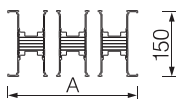
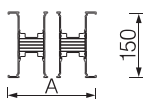
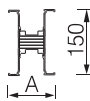

Figure 1

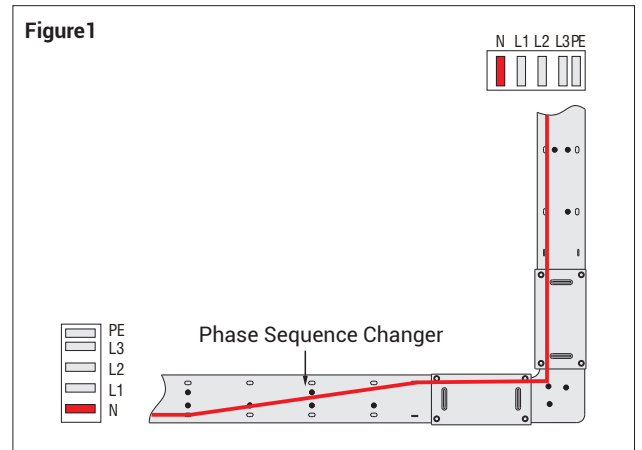
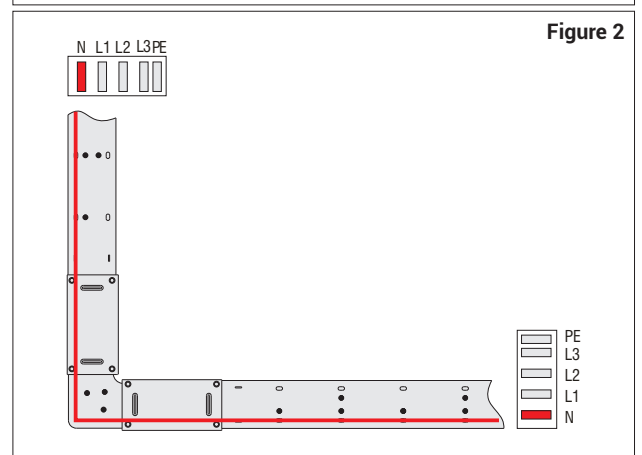
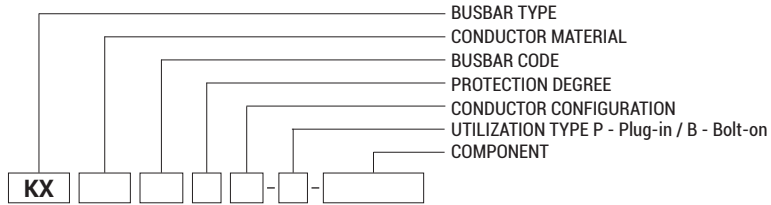

Figure 2



Vertical Shaft Application

- 1- The neutral bar of KX busbar shall be at the bottom for horizontal busbar lines and on the left for vertical busbar lines. (Figure 1)
- 2- In order to maintain the neutral bar at the bottom and in the vertical busbar on the left, it is required to use the phase changing module. (Figure 2)



- BUSBAR TYPE
- CONDUCTOR MATERIAL
- BUSBAR CODE
- PROTECTION DEGREE
- CONDUCTOR CONFIGURATION
- UTILIZATION TYPE P - Plug-in / B - Bolt-on
- COMPONENT



End Closer - S

Sample Order:
2500 A, Copper Bolt-on,
IP 55, 4½ conductors

KX-II 25 - B - S

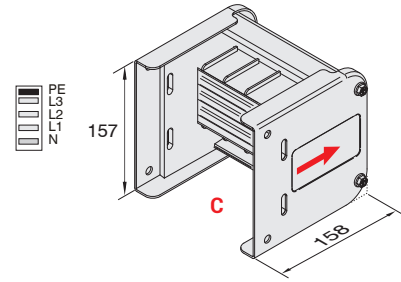

End Closer - S 1 0

Sample Order:
6300 A, Copper Bolt-on,
4½ conductors

KXC-II 63507 - B - S 10

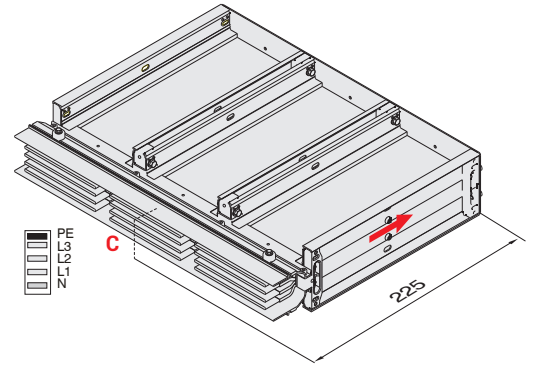

End Closer - S 1 1

Sample Order:
5000 A, Copper Bolt-on,
4½ conductors

KXC-II 50507 - B - S 11

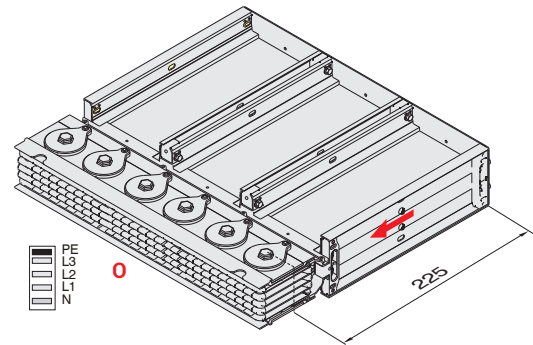

End Closer

Is used to close the end of busbar run.

KXA-II - Al Conductors		KXC-II - Cu Conductors		L1, L2, L3, N + Housing 04	
				L1, L2, L3, N, ½ PE + Housing 07	
				L1, L2, L3, N, PE + Housing 05	
Rated Current	Busbar Code	Rated Current	Busbar Code	Dimensions (mm)	Order Code
-	-	650	06	6x25	3066129
-	-	800	08	6x30	3066131
630	06	-	-	6x40	3016698
-	-	1000	10	6x45	3141273
800	08	1250	12	6x55	3016699
1000	10	-	-	6x60	3142393
-	-	1350	14	6x70	3016700
1250	12	1600	16	6x80	3016701
-	-	2000	20	6x110	3016702
1600	17	2250	21	6x125	3016703
-	-	2500	25	6x160	3016705
2000	20	-	-	6x170	3142394
2500	27	-	-	6x230	3135702
-	-	2250	24	2(6x55)	3016707
-	-	2750	28	2(6x70)	3127358
2350	21	3000	30	2(6x80)	3016706
2500	25	3300	32	2(6x95)	3135702
-	-	3600	36	2(6x110)	3016709
3000	32	4000	40	2(6x125)	3016711
3300	33	-	-	2(6x140)	3016712
-	-	5000	50	2(6x160)	3016713
4000	40	-	-	2(6x170)	3142439
5000	51	-	-	2(6x250)	3127359
-	-	6300	63	3(6x160)	3135704
6300	63	-	-	3(6x200)	3113537

Note: S10 or S11 modules should be used as end closer for the busbars with 08, 09, 06 codes and for all products.

■ Please call us for non-standard components. ■ The dimensions given above are minimum values.

BUSBAR TYPE
 CONDUCTOR MATERIAL
 BUSBAR CODE
 PROTECTION DEGREE
 CONDUCTOR CONFIGURATION
 UTILIZATION TYPE P - Plug-in / B - Bolt-on
 COMPONENT

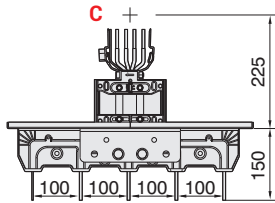
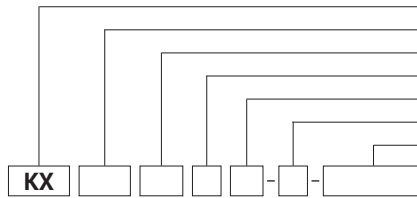

Panel Connection - P 1 0

Panel Feeder

Sample Order:
 2500 A, Copper, Bolt-on,
 4½ conductors for Panel Feeder

KXC-II 25507 - B - P10

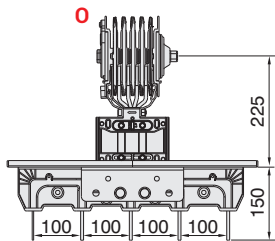
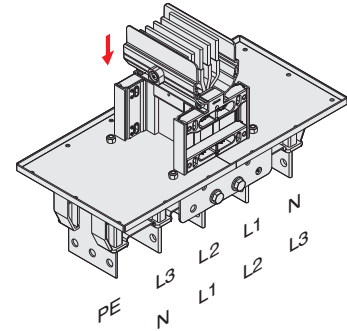

Panel Connection - P 1 1

Busbar Feeder

Sample Order:
 2500 A, Copper, Bolt-on,
 4½ conductors for Busbar Feeder

KXC-II 25507 - B - P11

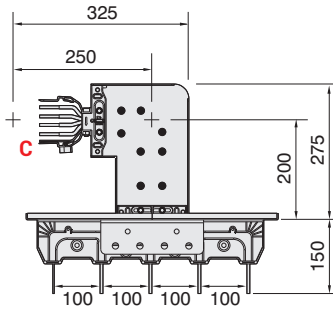
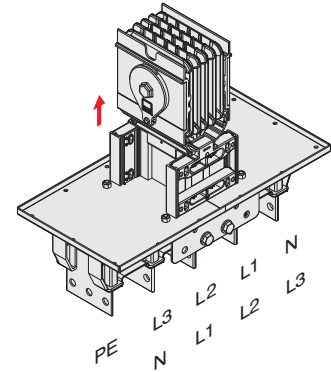

Upwards Panel Connection - P U 2 0

Panel Feeder

Sample Order:
 3600 A, Copper, Bolt-on,
 4½ conductors for Panel Feeder

KXC-II 36507 - B - PU20

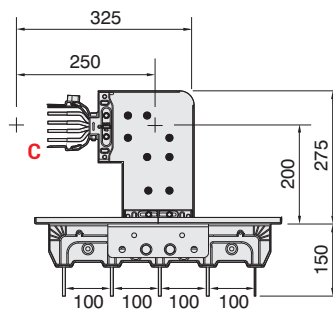
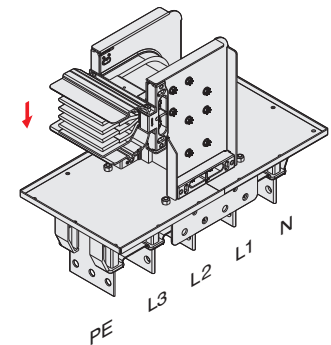

Downwards Panel Connection - P D 2 0

Panel Feeder

Sample Order:
 4000 A, Copper, Bolt-on,
 4½ conductors for Panel Feeder

KXC-II 40507 - B - PD20

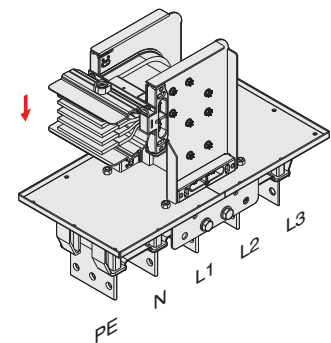

For connection dimensions please refer to tables on pages 24 and 25.

Note: Please contact with us for the dimensions of our 6 conductor solutions.

■ Distance between conductors can vary in ±5 mm.

■ Please call us for non-standard components.

■ The dimensions given above are minimum values.

BUSBAR TYPE
 CONDUCTOR MATERIAL
 BUSBAR CODE
 PROTECTION DEGREE
 CONDUCTOR CONFIGURATION
 UTILIZATION TYPE P - Plug-in / B - Bolt-on
 COMPONENT

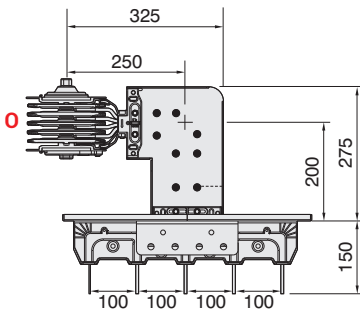
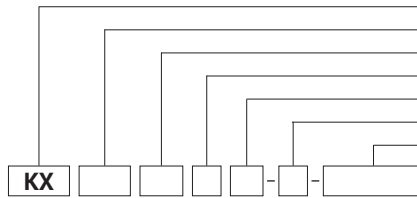

Upwards Busbar Connection Busbar Feeder - P U 2 1

Sample Order:
 3600 A, Copper, Bolt-on,
 4½ conductors for Busbar Feeder
KXC-II 36507 - B - PU21

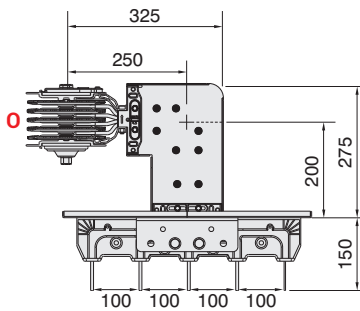
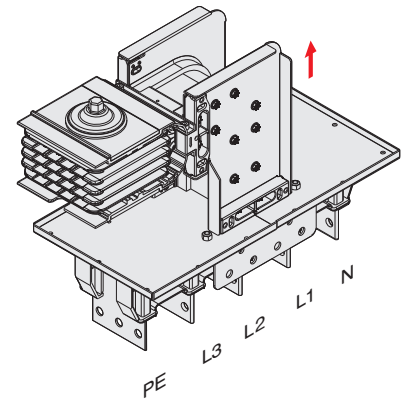

Downwards Busbar Connection Busbar Feeder - P D 2 1

Sample Order:
 4000 A, Copper, Bolt-on,
 4½ conductors for Busbar Feeder
KXC-II 40507 - B - PD21

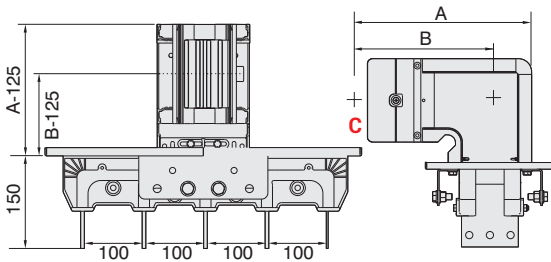
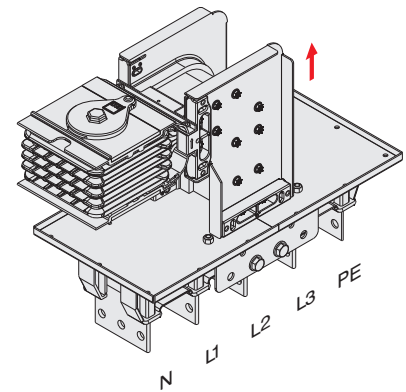

Right Panel Connection Panel Feeder - P R 3 0

Sample Order:
 2500 A, Copper, Bolt-on,
 4½ conductors for Panel Feeder
KXC-II 25507 - B - PR30

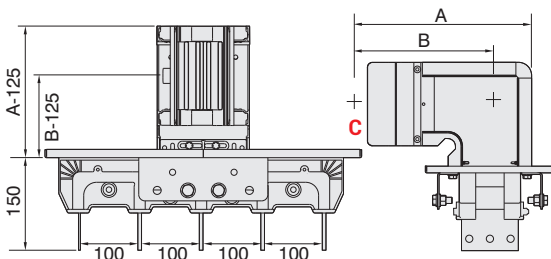
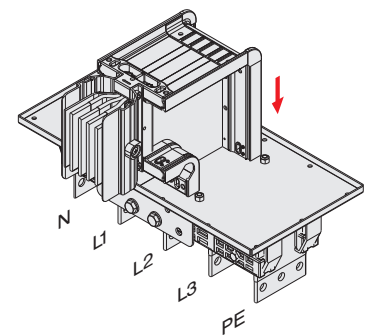

Left Panel Connection Panel Feeder - P L 3 0

Sample Order:
 2500 A, Copper, Bolt-on,
 4½ conductors for Panel Feeder
KXC-II 25507 - B - PL30

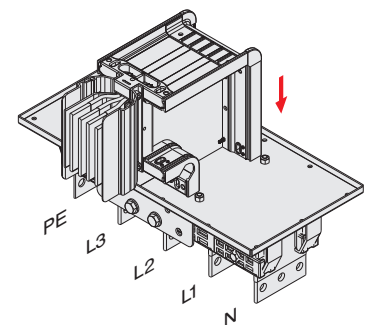

The "A" and "B" dimensions for PR30 and PL30 are the same dimensions as left and right elbows. Please refer to page 12 for the dimensions.

For connection dimensions please refer to tables on pages 24 and 25.

Note: Please contact with us for the dimensions of our 6 conductor solutions.

■ Distance between conductors can vary in ±5 mm. ■ Please call us for non-standard components. ■ The dimensions given above are minimum values.

- BUSBAR TYPE
- CONDUCTOR MATERIAL
- BUSBAR CODE
- PROTECTION DEGREE
- CONDUCTOR CONFIGURATION
- UTILIZATION TYPE P - Plug-in / B - Bolt-on
- COMPONENT

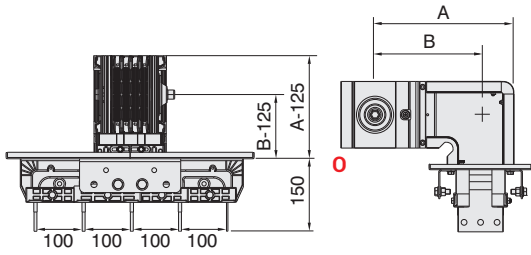
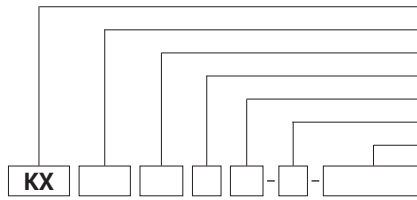

Right Panel Connection - P R 3 1

Busbar Feeder

Sample Order:
2500 A, Copper, Bolt-on,
4½ conductors for Busbar Feeder

KXC-II 25507 - B - PR31

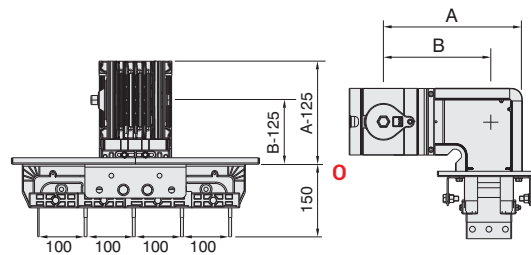
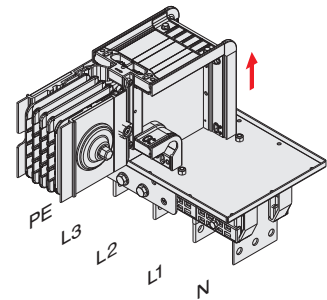

Left Panel Connection - P L 3 1

Busbar Feeder

Sample Order:
2500 A, Copper, Bolt-on,
4½ conductors for Busbar Feeder

KXC-II 25507 - B - PL31

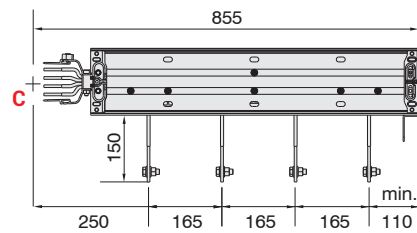
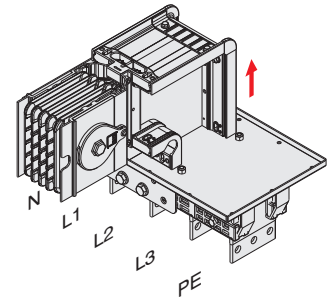

Panel Connection - P 4 0

Panel Feeder

Sample Order:
3300 A, Copper, Bolt-on,
4½ conductors for Panel Feeder

KXC-II 32507 - B - P40

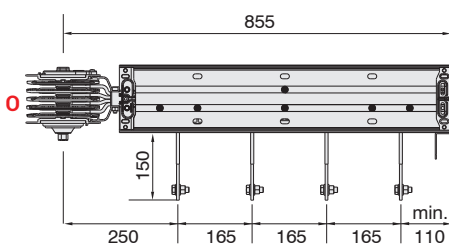
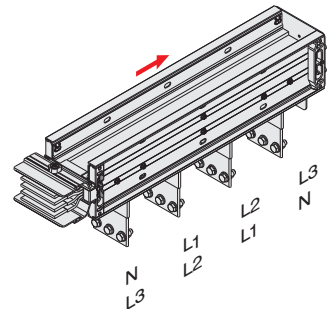

Panel Connection - P 4 1

Busbar Feeder

Sample Order:
3300 A, Copper, Bolt-on,
4½ conductors for Busbar Feeder

KXC-II 32507 - B - P41

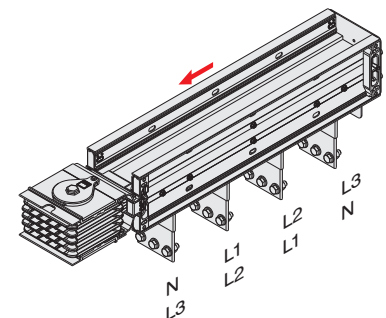

The "A" and "B" dimensions for PR31 and PL31 are the same dimensions as left and right elbows. Please refer to page 12 for the dimensions.

For connection dimensions please refer to tables on pages 24 and 25.

Note: Please contact with us for the dimensions of our 6 conductor solutions.

■ Distance between conductors can vary in ±5 mm. ■ Please call us for non-standard components. ■ The dimensions given above are minimum values.

Panel Connection Units

Panel Connection Units (P10, P11, PU20, PD20, PU21, PD21, PL30, PR30, PL31, PR31, P40, P41)

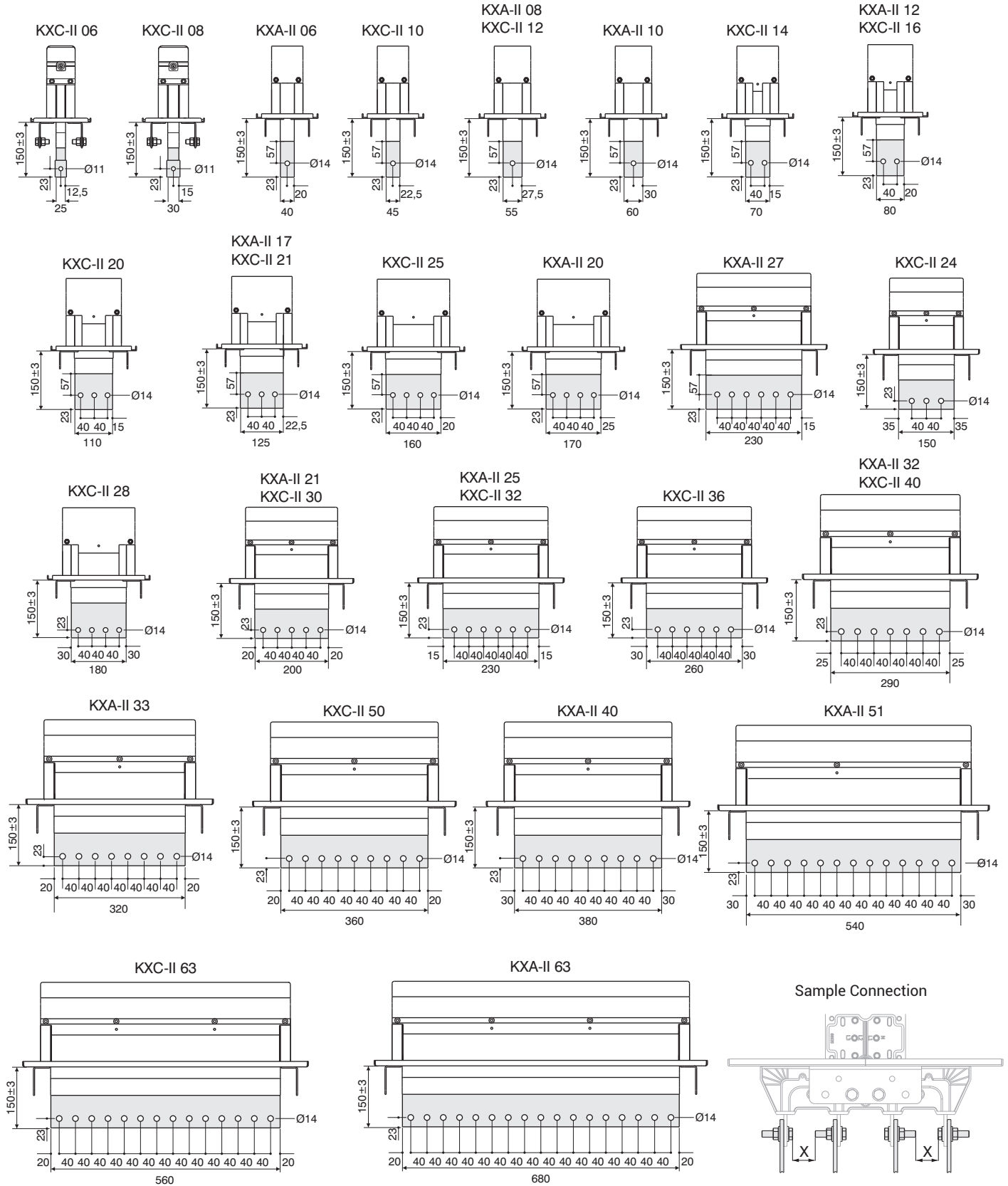

Sample Connection

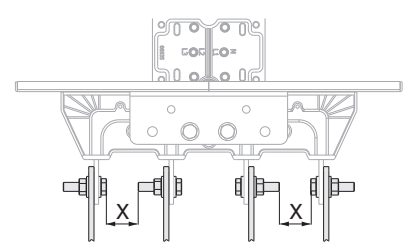

(Minimum X= 25 mm olmalıdır.)

Note: Please contact with us for the dimensions of our 6 conductor solutions.

■ Please call us for non-standard components. ■ Distance between conductors can vary in ±5 mm. ■ The dimensions given above are minimum values.

Flange Dimensions

Panel Connection Units are supplied with suitable flange as standard.

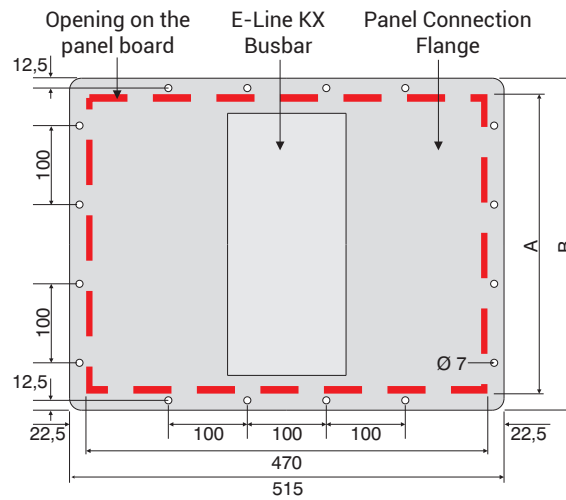
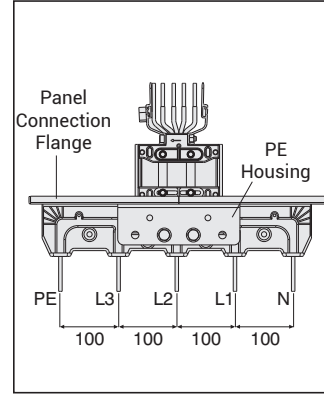
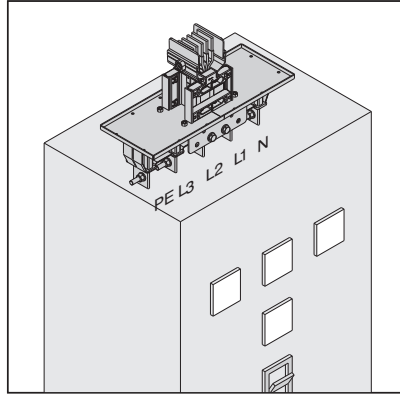

* Bolt and nut sets are supplied together with related product as per the quantities below.

Aluminium (Al)		Copper (Cu)		Conductor Size	A (mm)	B (mm)	Number of the holes along B length	* M6 Bolt/ Nut Set(pcs)
Rated Current	Busbar Code	Rated Current	Busbar Code					
-	-	650	06	6x25	120	165	2	12
-	-	800	08	6x30	125	170	2	12
630	06	-	-	6x40	135	180	2	12
-	-	1000	10	6x45	140	185	2	12
800	08	1250	12	6x55	150	195	2	12
1000	10	-	-	6x60	155	200	2	12
-	-	1350	14	6x70	165	210	2	12
1250	12	1600	16	6x80	175	220	2	12
-	-	2000	20	6x110	205	250	3	14
1600	17	2250	21	6x125	220	265	3	14
-	-	2500	25	6x160	255	300	3	14
2000	20	-	-	6x170	265	310	3	14
2500	27	-	-	6x230	325	370	4	16
-	-	2250	24	2(6x55)	245	290	3	14
-	-	2750	28	2(6x70)	275	320	3	14
2350	21	3000	30	2(6x80)	295	340	3	14
2500	25	3300	32	2(6x95)	325	370	4	16
-	-	3600	36	2(6x110)	355	400	4	16
3000	32	4000	40	2(6x125)	385	430	4	16
3300	33	-	-	2(6x140)	415	460	5	18
-	-	5000	50	2(6x160)	455	500	5	18
4000	40	-	-	2(6x170)	475	520	5	18
5000	51	-	-	2(6x250)	635	680	7	22
-	-	6300	63	3(6x160)	655	700	7	22
6300	63	-	-	3(6x200)	775	820	8	24

Note: Please contact with us for the dimensions of our 6 conductor solutions.

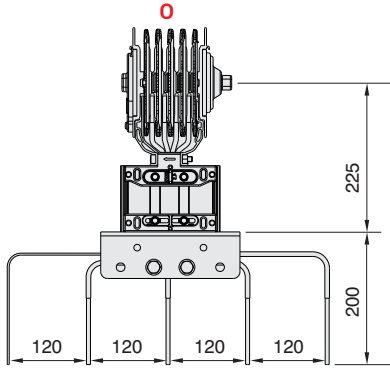
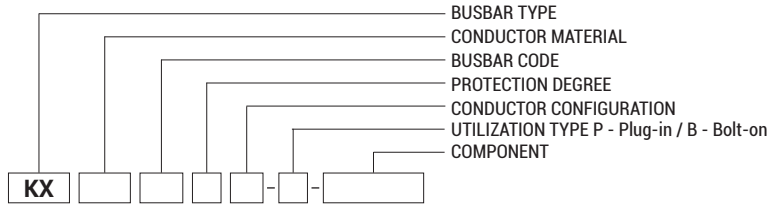

Transformer Connection - T R 1 1

Sample Order:
2500 A, Copper, Bolt-on,
4 ½ conductors

KXC-II 25507 - B - TR11-120

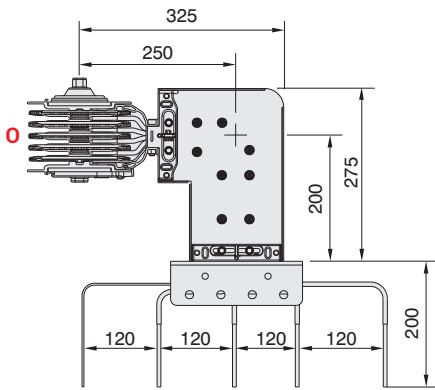
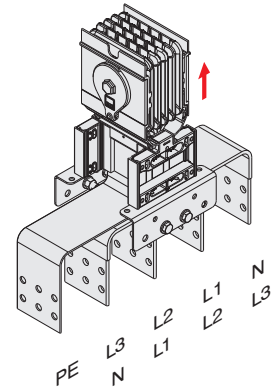

Upwards Transformer Connection - T U 2 1

Sample Order:
2500 A, Copper, Bolt-on,
4 ½ conductors

KXC-II 25507 - B - TU21-120

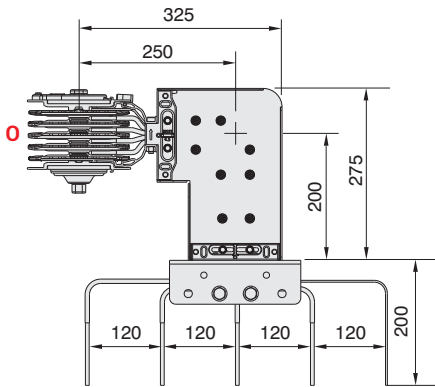
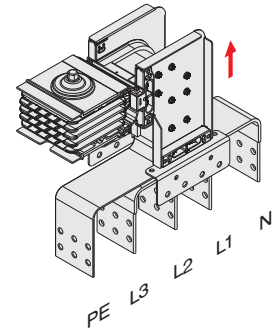

Downwards Transformer Connection - T D 2 1

Sample Order:
2500 A, Copper, Bolt-on,
4 ½ conductors

KXC-II 25507 - B - TD21-120

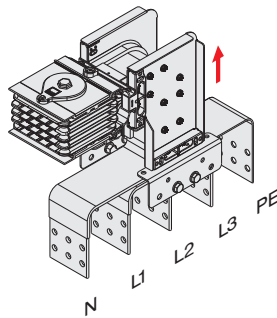

For connection dimensions please refer to tables on pages 29 and 30.

Note: Please contact with us for the dimensions of our 6 conductor solutions.

■ Distance between conductors can vary in ±5 mm. ■ Please call us for non-standard components. ■ The dimensions given above are minimum values.

ELINEKX-II

►► Transformer Connections

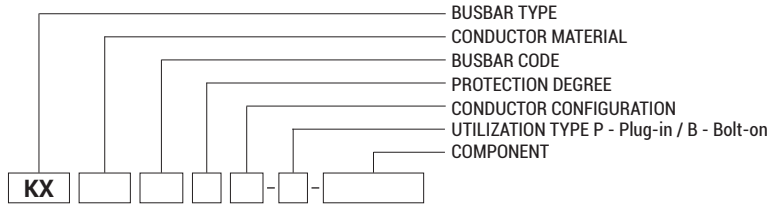

For transformer and panel connection applications EAE design and planning department can prepare your projects upon request.

For the design, the following information is required;

- Plan of transformer and panel board room, heights.
- Transformer dimensions, distance between bushings.

A and B dimensions of TR51 and TL51 are same as left and right elbows. Please refer to page 12 for the dimensions.

For connection dimensions please refer to tables on pages 29 and 30.

Flexible are used for

- Transformer - busbar,
- Panel - busbar connections.

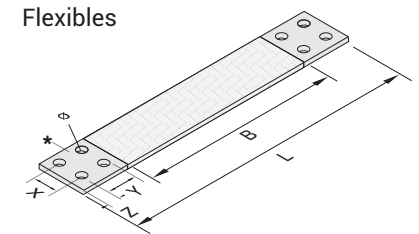
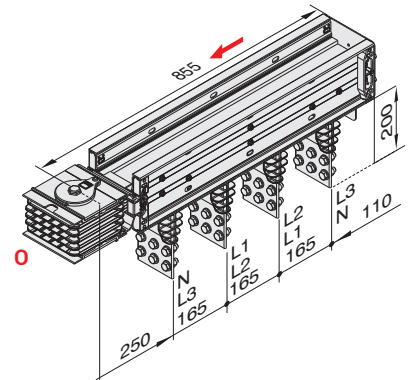

* This side is punched according to the needs of the customer.

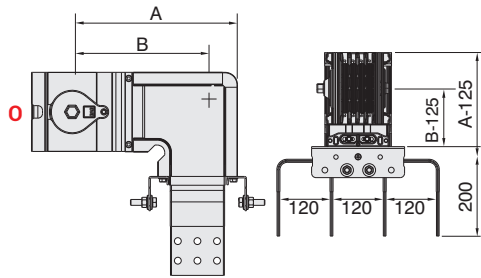
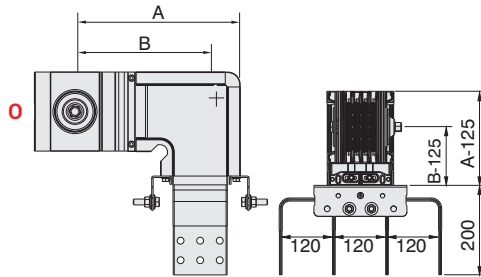

Transformer Connection - T R 3 1

Sample Order:
2500 A, Copper, Bolt-on,
4 ½ conductors

KXC-II 25507 - B - TR31

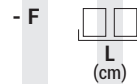

Sample Order:
800 A, Copper

KXC-II 0800 - F40

B=.....mm
X=.....mm
Y=.....mm
Z=.....mm
Ø=.....mm

Right Transformer Connection - T R 5 1

Sample Order:
2500 A, Copper, Bolt-on,
4 ½ conductors

KXC-II 25507 - B - TR51

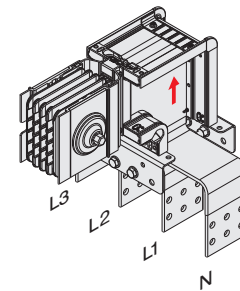

Left Transformer Connection - T L 5 1

Sample Order:
2500 A, Copper, Bolt-on,
4 ½ conductors

KXC-II 25507 - B - TL51

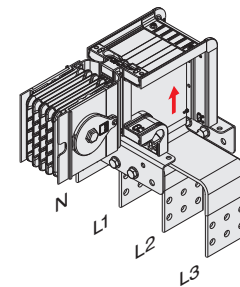

For connection dimensions please refer to tables on pages 29 and 30.

Note: Please contact with us for the dimensions of our 6 conductor solutions.

■ Distance between conductors can vary in ±5 mm. ■ Please call us for non-standard components. ■ The dimensions given above are minimum values.

ELINEKX-II

►► Transformer Connections

For transformer and panel connection applications EAE design and planning department can prepare your projects upon request.

For the design, the following information is required;

- Plan of transformer and panel board room, heights.
- Transformer dimensions, distance between bushings.
- Panel dimensions.

For connection dimensions please refer to tables on pages 29 and 30.

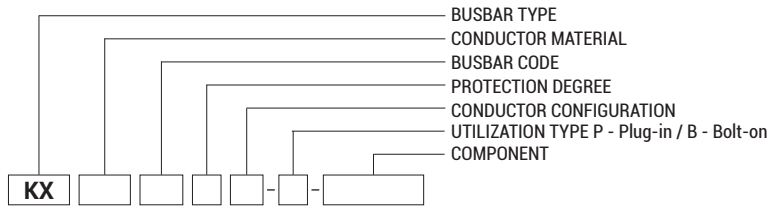

Transformer Connection - T R 4 1

Sample Order:
2500 A, Copper, Bolt-on,
4 ½ conductors

KXC-II 25507 - B - TR41

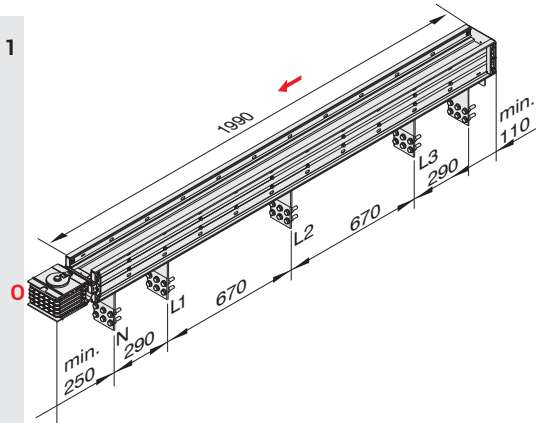

Transformer Connection - T R 6 1

Sample Order:
3600 A, Copper, Bolt-on,
4 ½ conductors

KXC-II 36507 - B - TR61

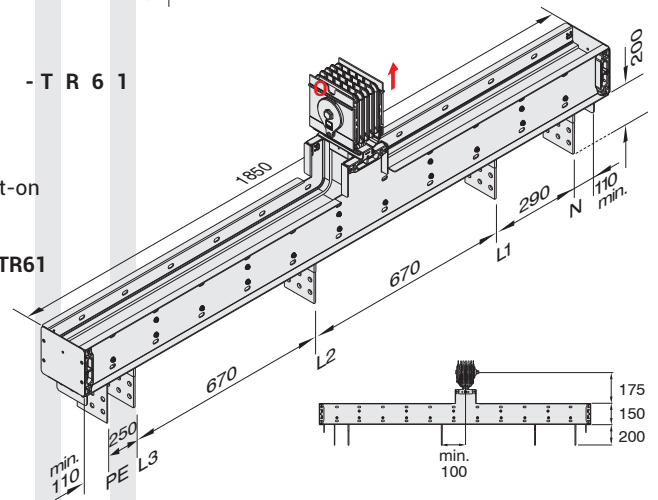

Transformer Connection - T R 7 1

Sample Order:
4000 A, Copper, Bolt-on,
4 ½ conductors

KXC-II 40507 - B - TR71

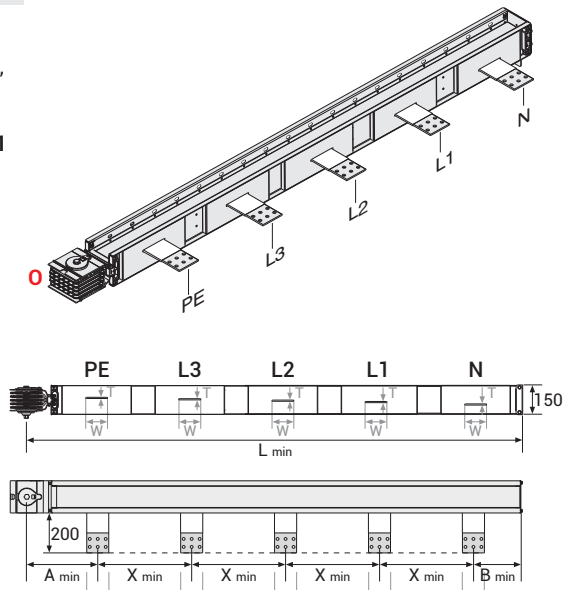

TR71 Dimension Table

KXA-II Al Conductor	KXC-II Cu Conductor	Conductor (+)	A	B	X	L		
Rated Current	Busbar Code	Rated Current	Busbar Code	T x W	(mm)	(mm)	(mm)	(mm)
-	-	*650	06	6x25	263	123	85	715
-	-	*800	08	6x30	265	125	90	730
*630	06	-	-	6x40	270	130	100	760
-	-	*1000	10	6x45	273	133	105	777
800	08	1250	12	6x55	278	138	115	805
1000	10	-	-	6x60	280	140	120	820
-	-	1350	14	6x70	285	145	130	850
1250	12	1600	16	6x80	290	150	140	880
-	-	2000	20	6x110	305	165	170	970
1600	17	2250	21	6x125	313	173	185	1015
-	-	2500	25	6x160	330	190	220	1120
2000	20	-	-	6x170	335	195	230	1150
2500	27	-	-	6x230	365	225	290	1330
-	-	2250	24	2(6x55)	278	138	115	805
-	-	2750	28	2(6x70)	285	145	130	850
2350	21	3000	30	2(6x80)	290	150	140	880
2500	25	3300	32	2(6x95)	298	158	155	925
-	-	3600	36	2(6x110)	305	165	170	970
3000	32	4000	40	2(6x125)	313	173	185	1015
3300	33	-	-	2(6x140)	320	180	200	1060
-	-	5000	50	2(6x160)	330	190	220	1120
4000	40	-	-	2(6x170)	335	195	230	1150
5000	51	-	-	2(6x250)	375	235	310	1390

(*) Note: The conductor cross-sectional values (T x W) are the same as the transformer connection conductor dimensions.

Sample (*): Single Line
2000 A, Copper, Bolt-on,
6x110 = TxW

T=6 W=110

Sample (*): Double Line
4000 A, Copper, Bolt-on,
2(6x125) = TxW

2T=12 W=125

Note: Please contact with us for the dimensions of our 6 conductor solutions.

Distance between conductors can vary in ±5 mm. Please call us for non-standard components. The dimensions given above are minimum values.

Transformer Connection Units

Transformer Connection Units (TL31, TR31, TR41, TR61, TR71)

Note: No flange supplied with transformer connection units.

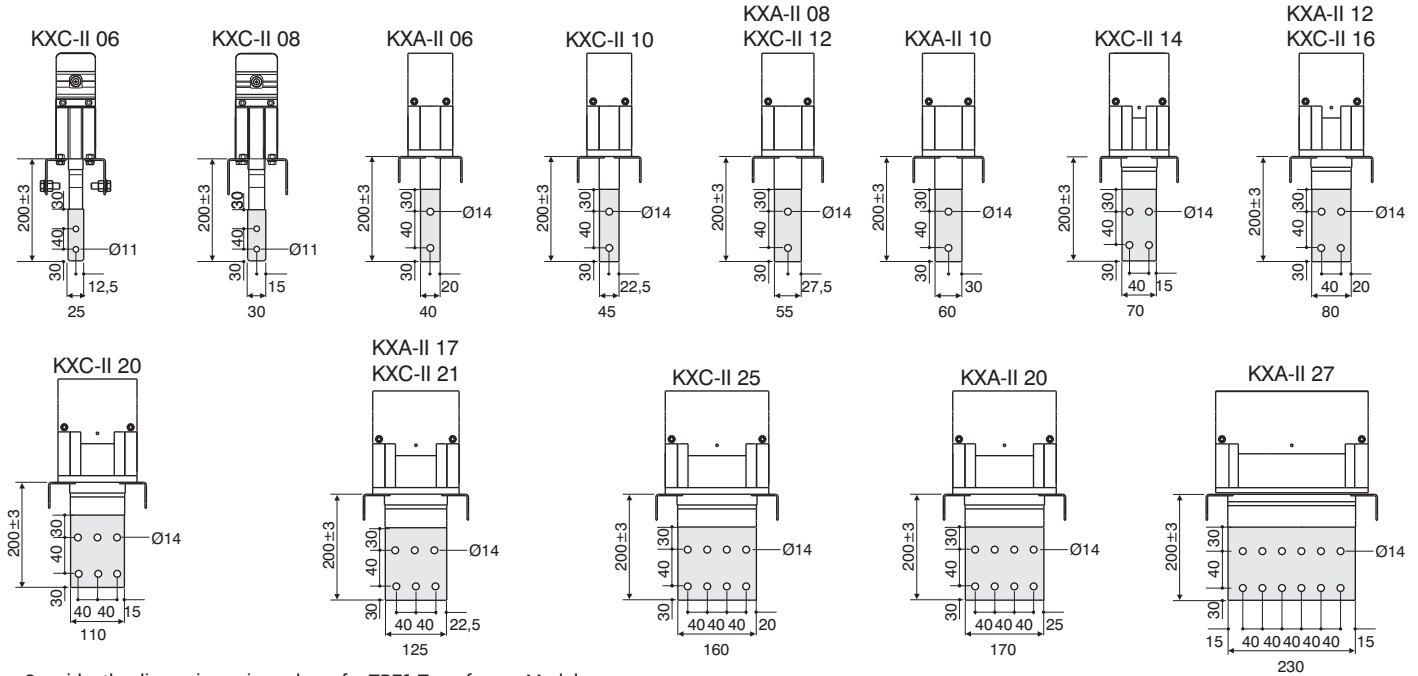

■ Consider the dimensions given above for TR71 Transformer Modules.

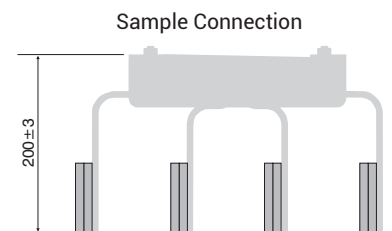
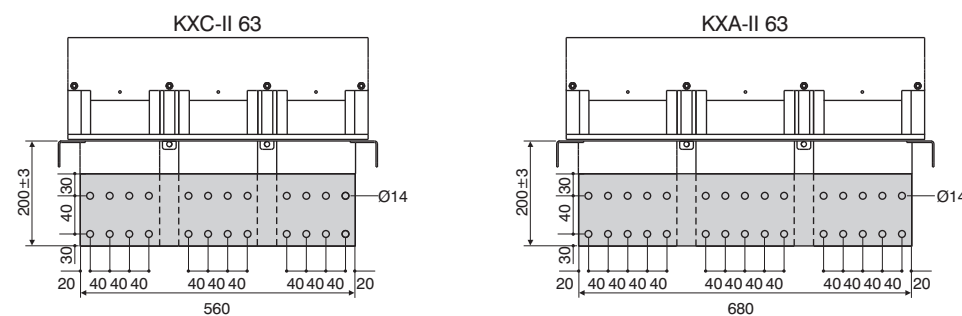
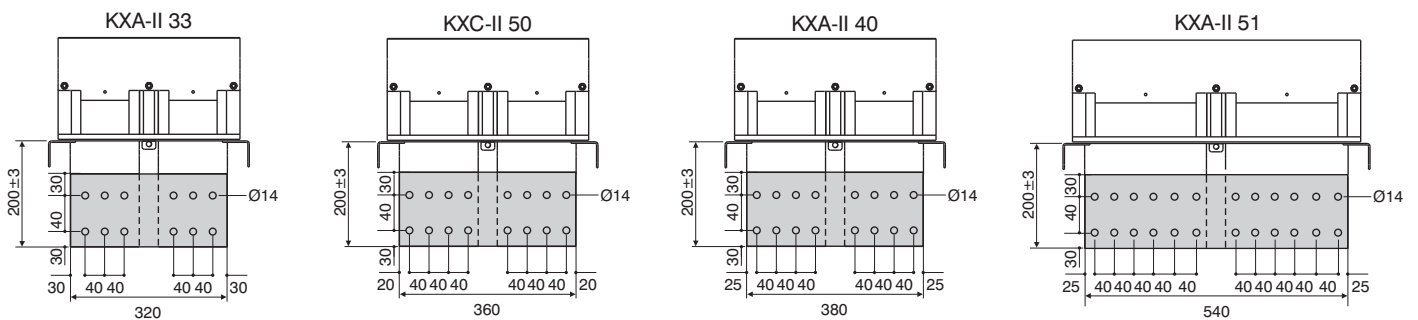
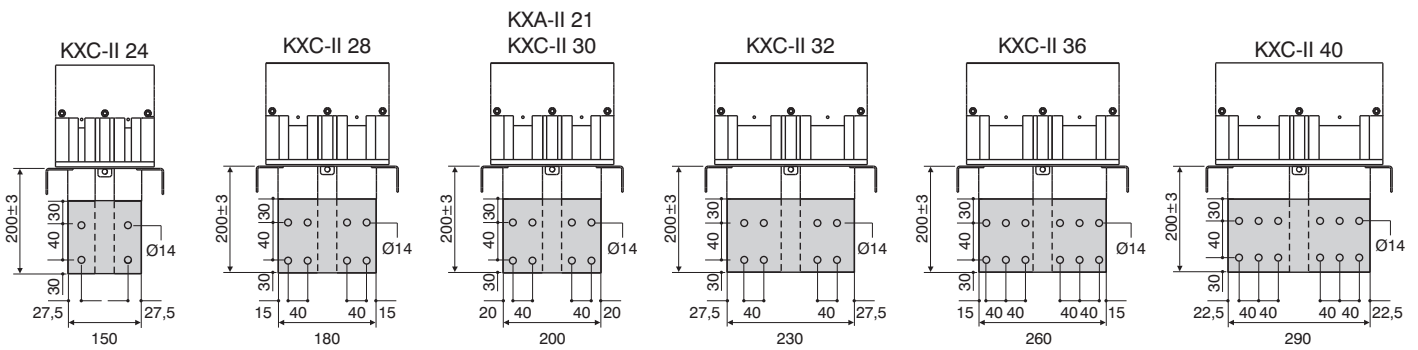

Note: Please contact with us for the dimensions of our 6 conductor solutions.

■ Please call us for non-standard components. ■ Distance between conductors can vary in ±5 mm. ■ The dimensions given above are minimum values.

Transformer Connection Units

Transformer Connection Units (TR11, TU21, TD21, TR51, TL51)

Note: No flange supplied with transformer connection units.

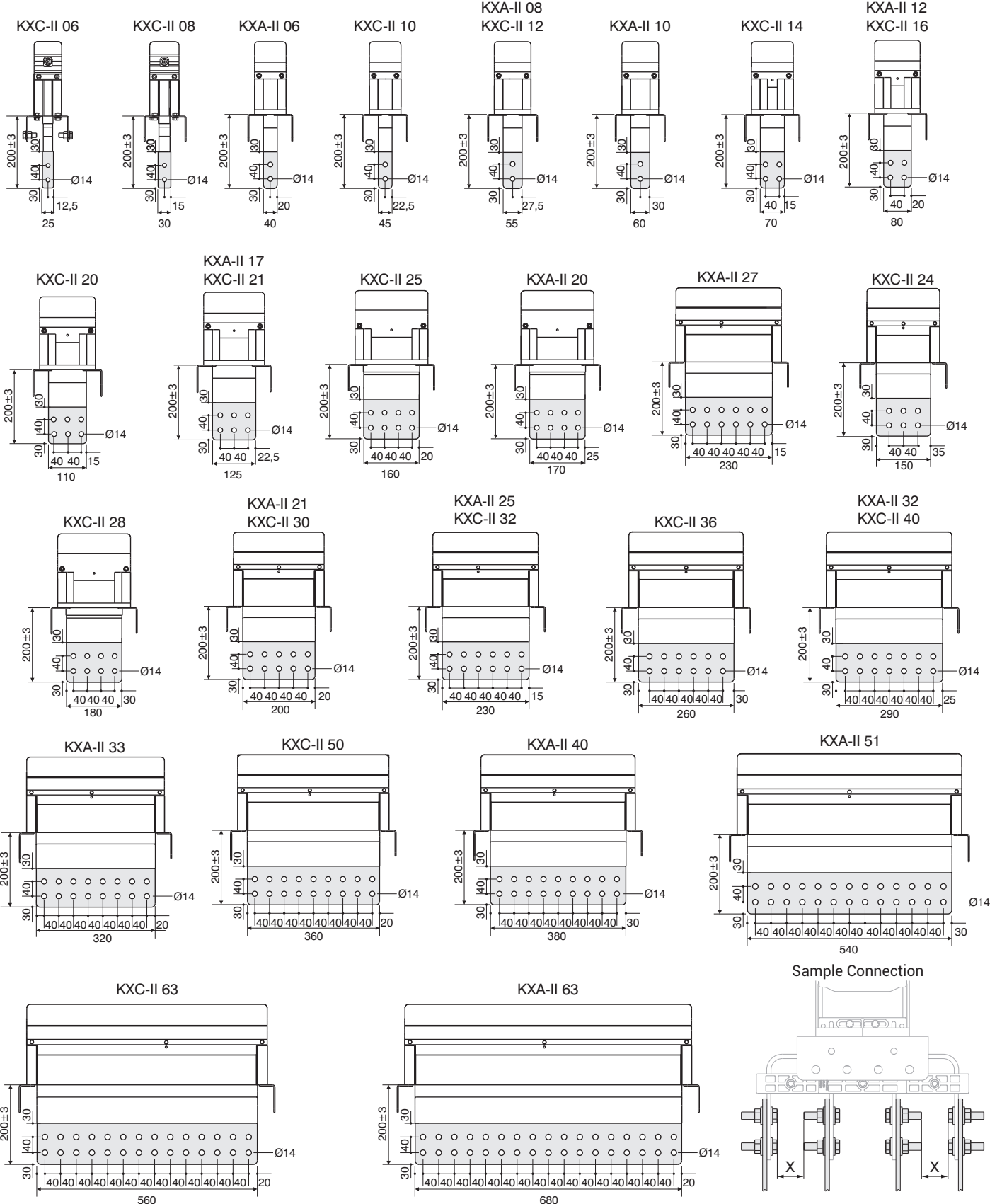

Note: Please contact with us for the dimensions of our 6 conductor solutions.

(Minimum X= 25 mm)

■ Please call us for non-standard components. ■ Distance between conductors can vary in ± 5 mm. ■ The dimensions given above are minimum values.

Easy Installation System of Tap-off Boxes

The patented hinge system is designed to allow the installation of plug-in tap-off boxes simply and easily

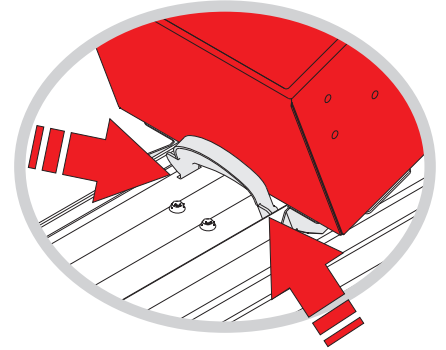
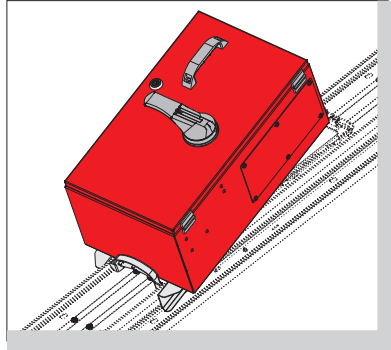
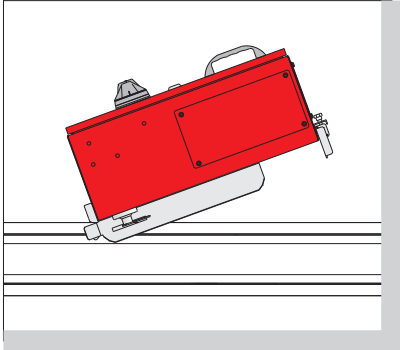

Fixing System of Tap-off Boxes to Busbars

Hook system, which is used for fixing of tap-off boxes on busbars.

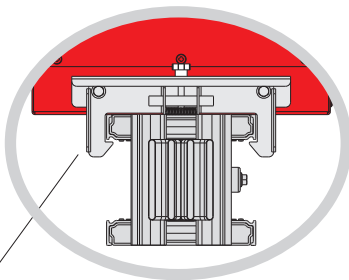
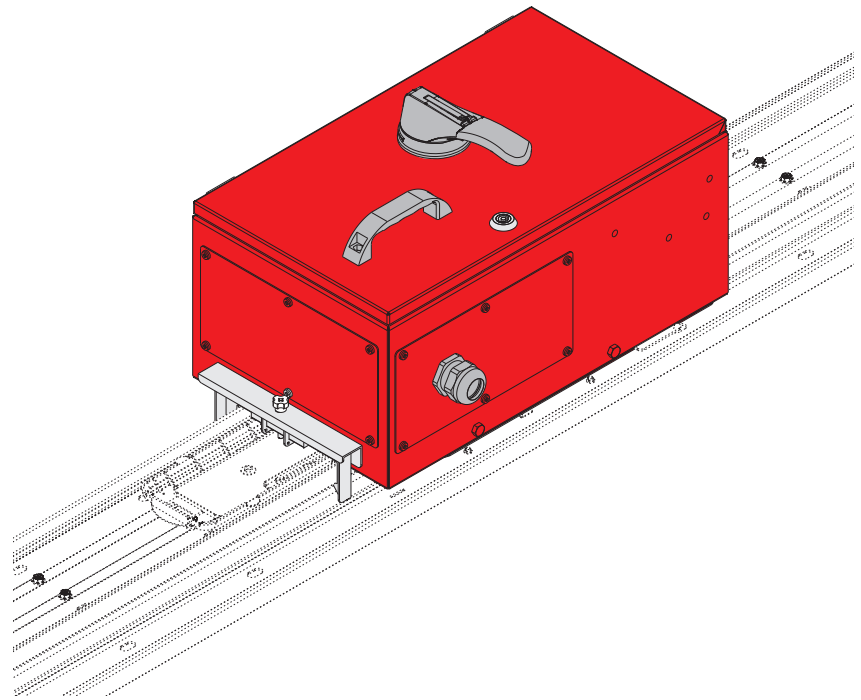
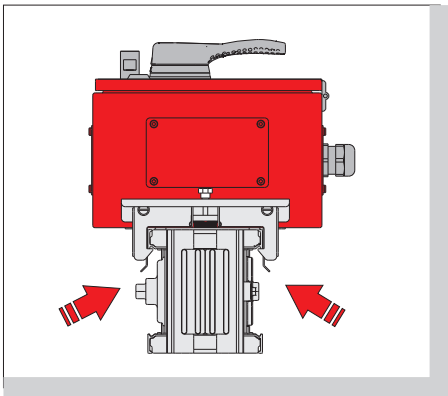

Locking Point

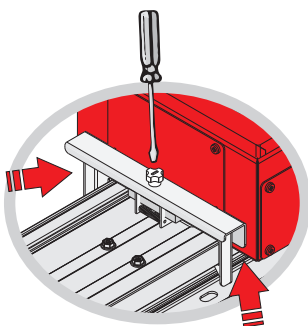

Universal Tap-off Boxes

Tap off boxes can be equipped with any brand of switches, circuit breakers and etc. Please inform EAE the type and brand of chosen MCCB, when ordering.

- Please call us for non-standard components.
- When requesting special size tap off boxes, make sure that the distance between the two plug point does not prevent the installation of the tap off boxes.

Side Opening Box Lids

A new generation of tap-off box with side opening lids enables easier connection to protective devices and maintenance.

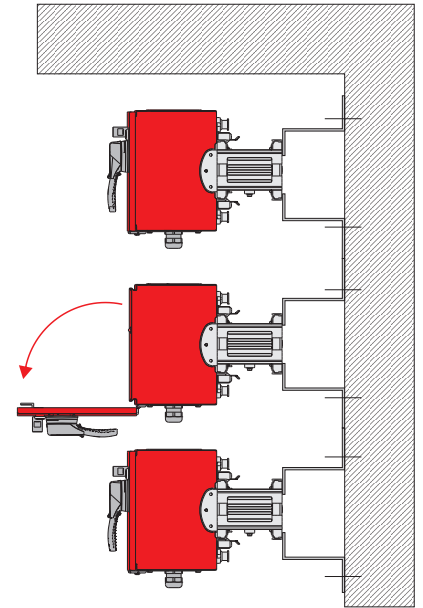
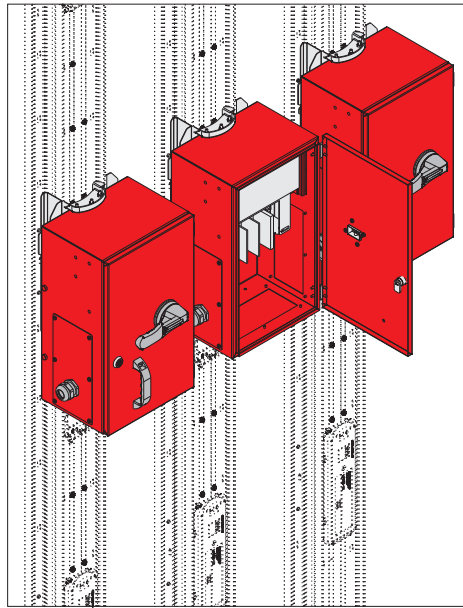

Bolt-on Tap-off Boxes

- Bolt-on tap-off boxes are designed to be installed at the joints without removing the joint block.
- The range of tap off boxes from 160A up to 1.000A.
- Busbar run must be de-energized before installing bolt-on tap-off boxes.

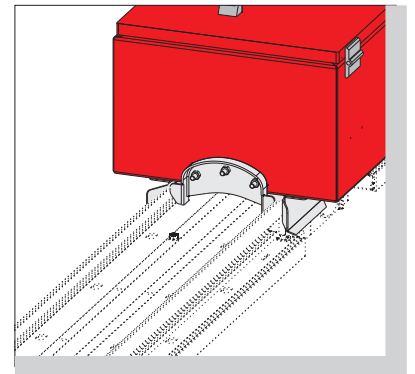
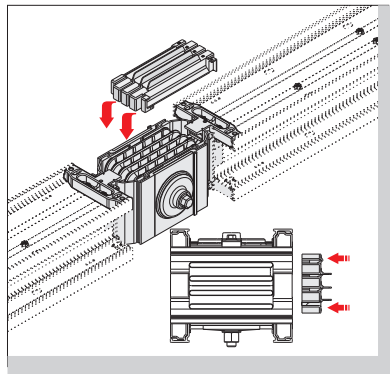

Effective Gasket

- Protection from dust and humidity due to effective gasket system.
- High IP Protection due to special forming.

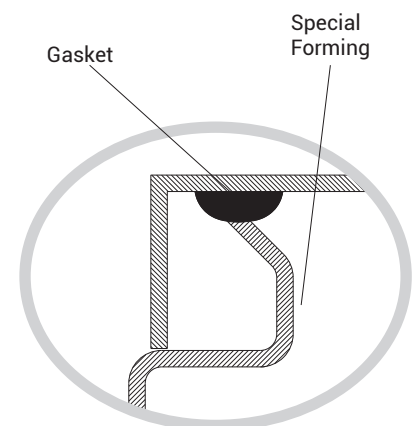
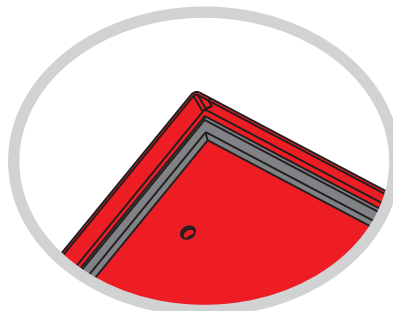
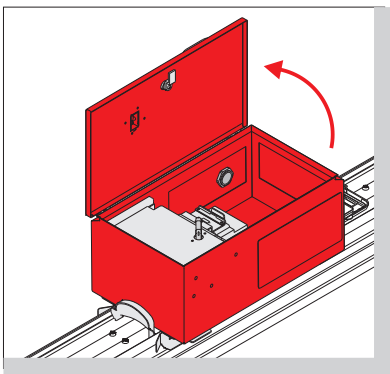

■ Please call us for non-standard components.

■ When requesting special size tap off boxes, make sure that the distance between the two plug point does not prevent the installation of the tap off boxes.

ELINEKX-II

▶▶ Tap-off Boxes with Fused Switches (Bolt-on-KXB)

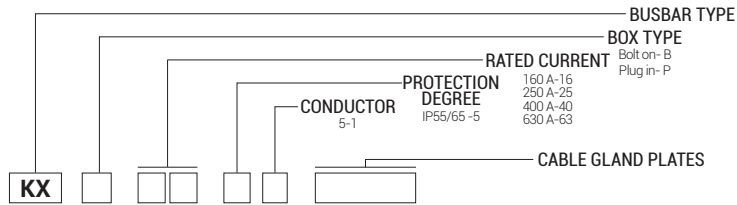

Cable Gland Plates

Mat. Sheet	Cable Gland Type	Order Code	Inner Diameter (mm)
Sheet	----	RP0	----
Sheet	M32	RP1	25
Sheet	M40	RP2	32
Sheet	Special	RP3	63
AL	2x Special	RP4	63
AL	4xM25	RP5	18
AL	4xM32	RP6	25
AL	4xM40	RP7	32
AL	8xM32	RP8	25

Notes::

EAE Bolt-on Tap Off Boxes are secured with an interlocking mechanism. This protects against attaching them to or removing them from the busbar in the "ON" position. When in the "OFF" position they are safe to attach to or remove from the busbar.

- Tap off boxes shall not be used empty. Fused switches, MCCBs or similar protection devices must be installed into tap-off boxes before they are installed to the busbar runs.

Bolt-on Tap-off Boxes

- KX B 1 6 5 1
- KX B 2 5 5 1
- KX B 4 0 5 1
- KX B 6 3 5 1

Sample Order:

Bolt-on / 630 A / IP-55 / 5 conductors
KXB 6351

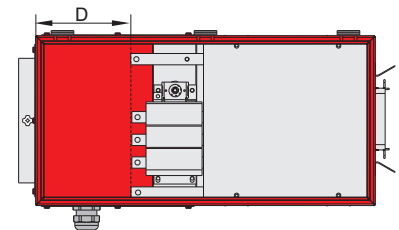
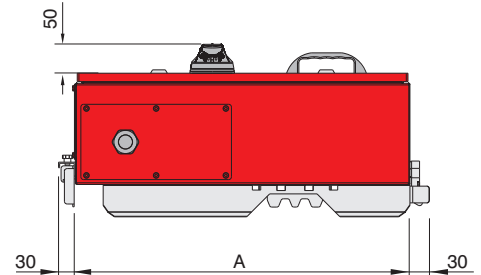
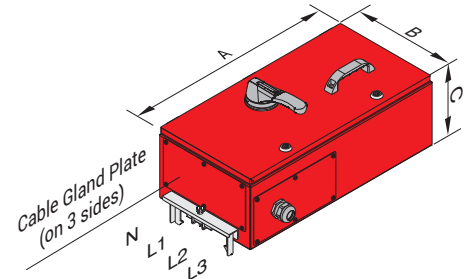

Bolt-on tap-off box can not be used on the joints of mentioned ranges of busbars.

Tap-off Boxes	A (mm)	B (mm)	C (mm)	D (mm)	Fuse Size	Standard Gland
KXB 16	750	380	240	265	NH 1	RP2
KXB 25	750	380	240	265	NH 1	RP3
KXB 40	850	420	260	265	NH 3	RP4
KXB 63	850	420	260	265	NH 3	RP4

KXA-II - Al Conductor		KXC-II - Cu Conductor		Bolt-on Tap-off Box
Rated Current	Busbar Code	Rated Current	Busbar Code	
-	-	650	06	x
-	-	800	08	x
630	06	1000	10	x

Gland Type	Max. External Diameter of Cable Cross-section (mm)
M25	Ø 18
M32	Ø 26
M40	Ø 33
M50	Ø 39
M63	Ø 45
Special for EAE	Ø 60

Tap-off boxes can be equipped with any brand of switches, circuit breakers and etc.

■ Please call us for non-standard components.

■ When requesting special size tap off boxes, make sure that the distance between the two plug point does not prevent the installation of the tap off boxes.

ELINEKX-II

▶▶ Tap-off Boxes with Fused Switches (Plug-in-KXP)

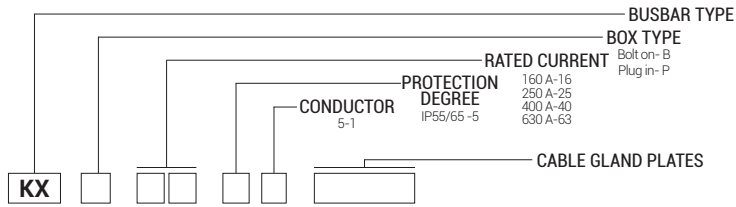

Cable Gland Plates

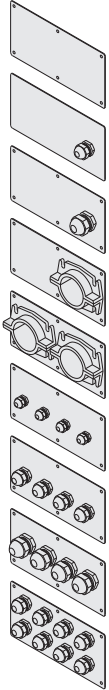

Mat. Sheet	Cable Gland Type	Order Code	Inner Diamete (mm)
Sheet	----	RP0	----
Sheet	M32	RP1	25
Sheet	M40	RP2	32
Sheet	Special	RP3	63
AL	2x Special	RP4	63
AL	4xM25	RP5	18
AL	4xM32	RP6	25
AL	4xM40	RP7	32
AL	8xM32	RP8	25

Plug-in Tap-off Boxes

- KX P 1 6 5 1
- KX P 2 5 5 1
- KX P 4 0 5 1
- KX P 6 3 5 1

Sample Order:

Plug-in / 630 A / IP-55 / 5 conductors

KXP 6351

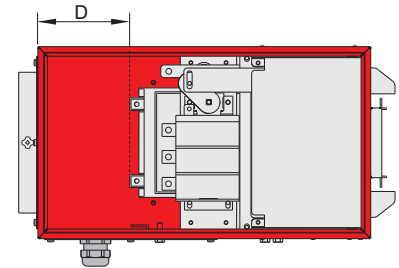
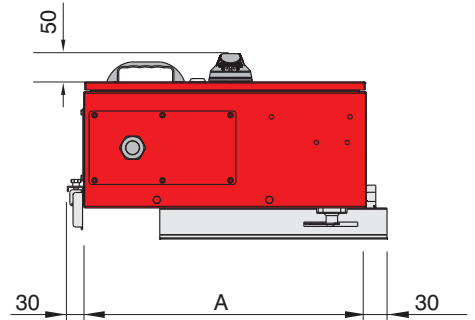
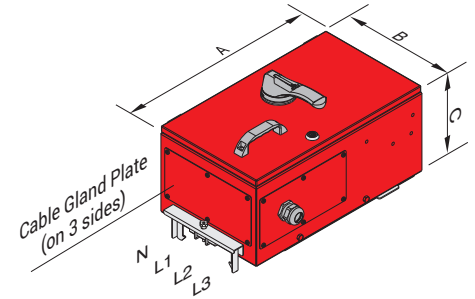

Notes:

EAE Plug-in Tap Off Boxes are secured with an interlocking mechanism. This protects against attaching them to or removing them from the busbar in the "ON" position. When in the "OFF" position they are safe to attach to or remove from the busbar.

- Tap off boxes shall not be used empty. Fused switches, MCCBs or similar protection devices must be installed into tap-off boxes before they are installed to the busbar runs.

Tap-off Boxes	A (mm)	B (mm)	C (mm)	D (mm)	Fuse Size	Standard Gland
KXP 16	520	300	210	140	NH00	RP2
KXP 25	670	380	270	290	NH 1	RP3
KXP 40	750	420	300	285	NH 3	RP4
KXP 63	750	420	300	285	NH 3	RP4

Gland Type	Max. External Diameter of Cable Cross-section (mm)
M25	Ø 18
M32	Ø 26
M40	Ø 33
M50	Ø 39
M63	Ø 45
Special for EAE	Ø 60

Tap-off boxes can be equipped with any brand of switches, circuit breakers and etc.

■ Please call us for non-standard components.

■ When requesting special size tap off boxes, make sure that the distance between the two plug point does not prevent the installation of the tap off boxes.

ELINEKX-II

▶▶ Tap-off Boxes for MCCB's (KXB)

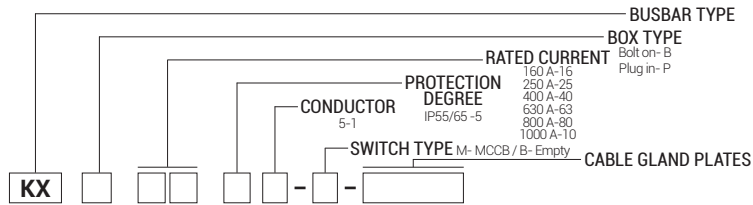

Cable Gland Plates

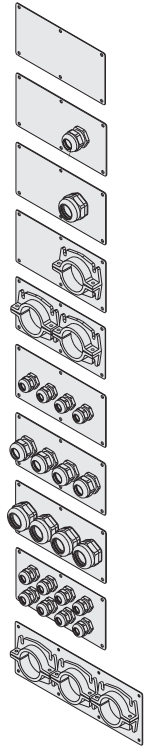

Mat.	Cable Gland Type	Order Code	Inner Diameter (mm)
Sheet	----	RP0	----
Sheet	M32	RP1	25
Sheet	M40	RP2	32
Sheet	Special	RP3	63
AL	2x Special	RP4	63
AL	4xM25	RP5	18
AL	4xM32	RP6	25
AL	4xM40	RP7	32
AL	8xM32	RP8	25
AL	3x Special	RP9	63

Special Cable Gland Plates

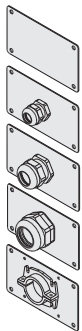

Mat.	Cable Gland Type	Order Code	Inner Diameter (mm)
Sheet	----	RPK0	----
Sheet	M25	RPK1	18
Sheet	M32	RPK2	25
Sheet	M40	RPK3	32
Sheet	1x Special	RPK4	63

Bolt-on Tap-off Boxes

- KX B 1 6 5 1 - B
- KX B 2 5 5 1 - B
- KX B 4 0 5 1 - B
- KX B 6 3 5 1 - B
- KX B 1 6 5 1 - M
- KX B 2 5 5 1 - M
- KX B 4 0 5 1 - M
- KX B 6 3 5 1 - M

Sample Order:

Bolt-on / 630 A / IP-55 / 5 conductors, empty tap-off box

KXB 6351 - B

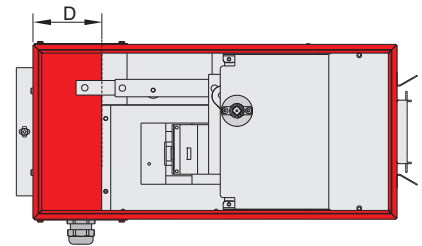
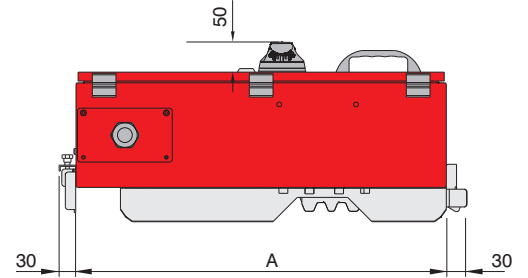
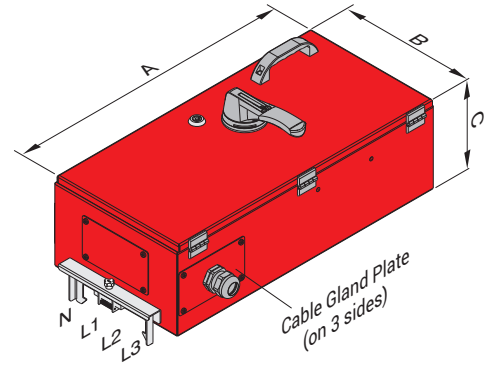

- KX B 8 0 5 1 - B
- KX B 1 0 5 1 - B
- KX B 8 0 5 1 - M
- KX B 1 0 5 1 - M

Sample Order:

Bolt-on / 800 A / IP-55 / 5 conductors, empty tap-off box

KXB 8051 - B

Bolt-on tap-off box can not be used on the joints of mentioned ranges of busbars.

Tap-off Boxes	A (mm)	B (mm)	C (mm)	*D (mm)	Standard Gland
KXB 16	650	300	220	130	RPK3
KXB 25	650	300	220	130	RPK4
KXB 40	800	300	220	210	RP4
KXB 63	800	300	220	210	RP4
KXB 80	1100	450	275	385	RP9
KXB 10	1100	450	275	385	RP9

KXA-II - Al Conductor		KXC-II - Cu Conductor		Bolt-on Tap-off Box
Rated Current	Busbar Code	Rated Current	Busbar Code	
-	-	650	06	x
-	-	800	08	x
630	06	1000	10	x

Gland Type	Max. External Diameter of Cable Cross-section (mm)
M25	Ø 18
M32	Ø 26
M40	Ø 33
M50	Ø 39
M63	Ø 45
Special for EAE	Ø 60

* D value varies as per the used switch.

* Tap-off boxes can be equipped with any brand of MCCB's.

■ Please call us for non-standard components.

■ When requesting special size tap off boxes, make sure that the distance between the two plug point does not prevent the installation of the tap off boxes.

ELINEKX-II

▶▶ Tap-off Boxes for MCCB's (KXP)

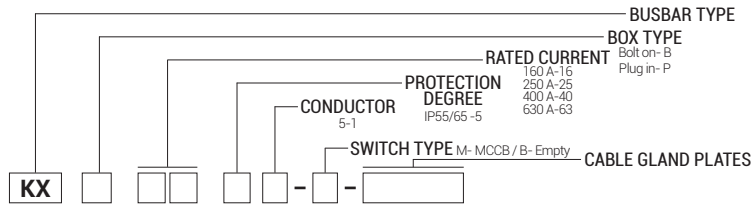

Cable Gland Plates

Mat.	Cable Gland Type	Order Code	Inner Diameter (mm)
Sheet	----	RP0	----
Sheet	M32	RP1	25
Sheet	M40	RP2	32
Sheet	Special	RP3	63
AL	2x Special	RP4	63
AL	4xM25	RP5	18
AL	4xM32	RP6	25
AL	4xM40	RP7	32
AL	8xM32	RP8	25

Plug-in Tap-off Boxes

- KX P 1 6 5 1 - B 1
- KX P 2 5 5 1 - B 1
- KX P 4 0 5 1 - B 1
- KX P 6 3 5 1 - B 1
- KX P 1 6 5 1 - M 1
- KX P 2 5 5 1 - M 1
- KX P 4 0 5 1 - M 1
- KX P 6 3 5 1 - M 1

Sample Order:

Plug-in / 400 A / IP-55 / 5 conductors, empty tap-off box

KXP 4051 - B1

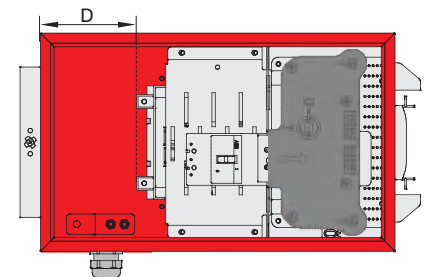
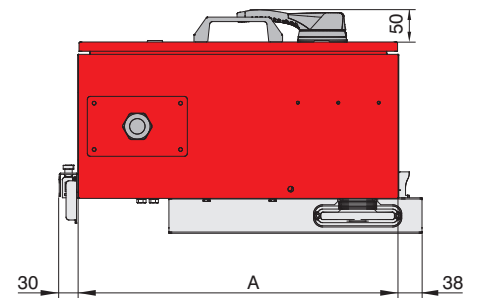
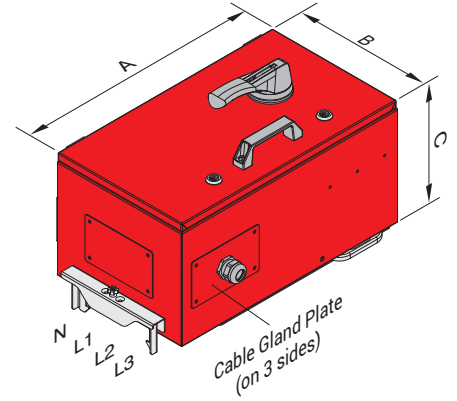

Special Cable Gland Plates

Mat	Cable Gland Type	Order Code	Inner Diameter (mm)
Sheet	----	RPK0	----
Sheet	M25	RPK1	18
Sheet	M32	RPK2	25
Sheet	M40	RPK3	32
Sheet	1x Special	RPK4	63

Tap-off Boxes	A (mm)	B (mm)	C (mm)	D (mm)	Standard Gland
KXP 16	520	320	250	150	RPK3
KXP 25	520	320	250	150	RPK4
KXP 40	700	320	250	255	RP4
KXP 63	700	320	250	255	RP4

Gland Type	Max. External Diameter of Cable Cross-section (mm)
M25	Ø 18
M32	Ø 26
M40	Ø 33
M50	Ø 39
M63	Ø 45
Special for EAE	Ø 60

* D value varies as per the used switch.

* Tap-off boxes can be equipped with any brand of MCCB's.

■ Please call us for non-standard components.

■ When requesting special size tap off boxes, make sure that the distance between the two plug point does not prevent the installation of the tap off boxes.

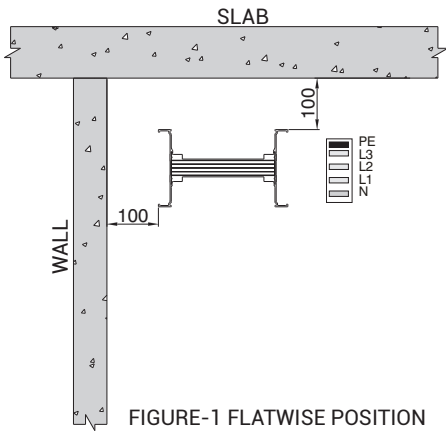

FIGURE-1 FLATWISE POSITION

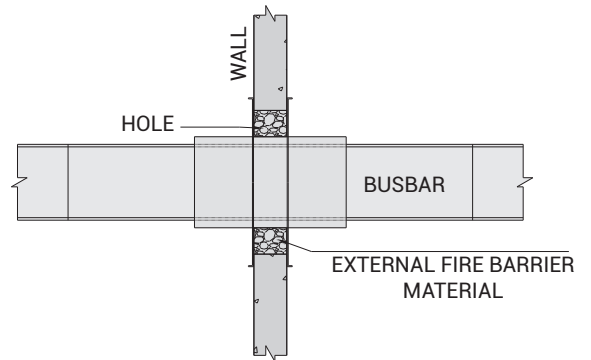

FIGURE-5 SAMPLE WALL CROSSING WITH FIRE BARRIER

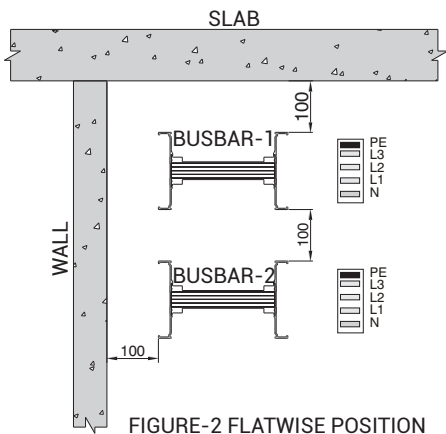

FIGURE-2 FLATWISE POSITION

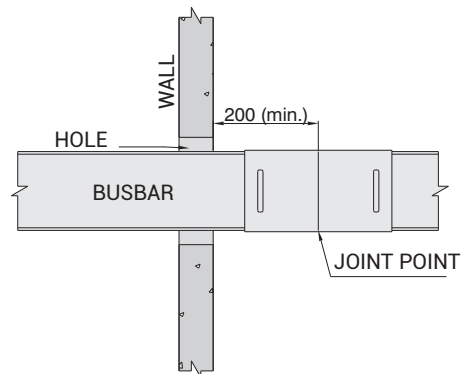

FIGURE-6 STANDARD WALL CROSSING

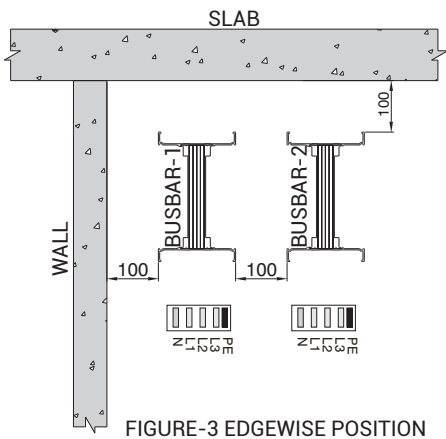

FIGURE-3 EDGEWISE POSITION

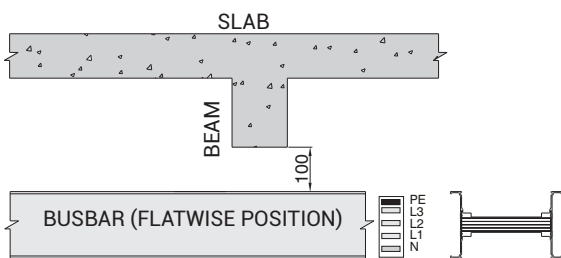
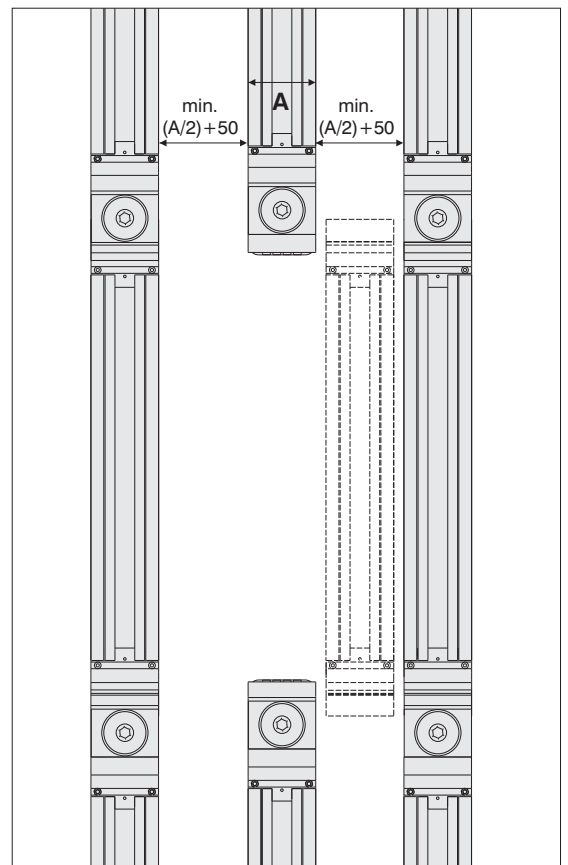

FIGURE-4 CROSSING UNDER A BEAM HORIZONTAL POSITION



MINIMUM DISTANCE BETWEEN BUSBAR RUNS IN HORIZONTAL APPLICATIONS.

■ The dimensions given above are minimum values. ■ All measures are given in mm.

ELINEKX-II

►► Feeder Boxes (B10,B11)

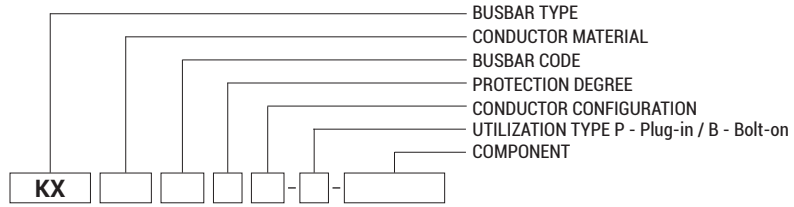

Cable Gland Plates

Busbar Housing Type	Cable Gland Plate	Type
		1
		2
		3
		2
		3
		4

Feeder Box B10 - B 1 0

Sample Order:
3200 A, Aluminium, Bolt-on
4 conductors

KXC-II 32507 - B - B10

Feeder Box B11 - B 1 1

Sample Order:
3600 A, Copper,
Bolt-on, 4 conductors

KXC-II 36507 - B - B11

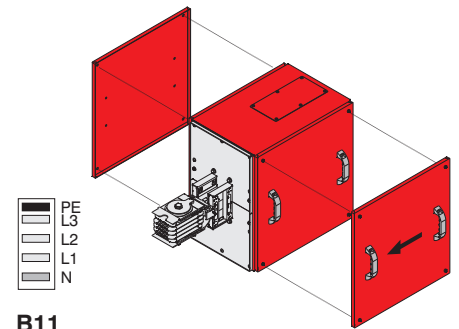
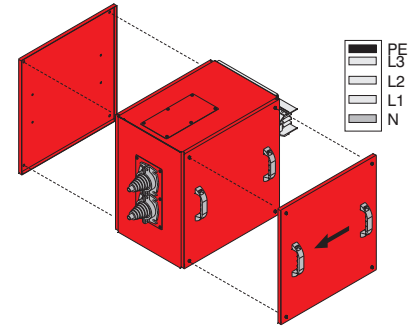

B11

Ampere Ratings

KXA-II Al Conductor		KXC-II Cu Conductor		A	B	C	D	Gland Type
Rated Current	Busbar Code	Rated Current	Busbar Code	(mm)	(mm)	(mm)	(mm)	(mm)
-	-	*650	06	500	520 / 620*	355	350	1
-	-	*800	08	500	520 / 620*	355	350	1
630	06	-	-	500	520 / 620	355	350	1
-	-	*1000	10	500	520 / 620*	355	350	1
800	08	1250	12	500	520 / 620*	355	350	1
1000	10	-	-	500	520 / 620*	355	350	1
-	-	1350	14	500	520 / 620*	355	350	1
1250	12	1600	16	500	520 / 620*	355	350	1
-	-	2000	20	500	520 / 620*	355	350	1
1600	17	2250	21	500	520 / 620*	555	350	2
-	-	2500	25	500	520 / 620*	555	350	2
2000	20	-	-	500	520 / 620*	555	350	2
2500	27	-	-	500	520 / 620*	555	350	3
-	-	2250	24	500	520 / 620*	555	350	2
-	-	2750	28	500	520 / 620*	555	350	3
2350	21	3000	30	500	520 / 620*	555	350	3
2500	25	3300	32	500	520 / 620*	555	350	3
-	-	3600	36	500	520 / 620*	555	350	3
3000	32	4000	40	500	520 / 620*	555	350	3
3300	33	-	-	700	520 / 620*	770	550	3
-	-	5000	50	700	520 / 620*	770	550	3
4000	40	-	-	700	520 / 620*	770	550	3
5000	51	-	-	700	520 / 620*	770	550	3
-	-	6300	63	700	520 / 620*	950	550	4
6300	63	-	-	700	520 / 620*	950	550	4

*The values are given for 08 and 09 codes clean earth models.

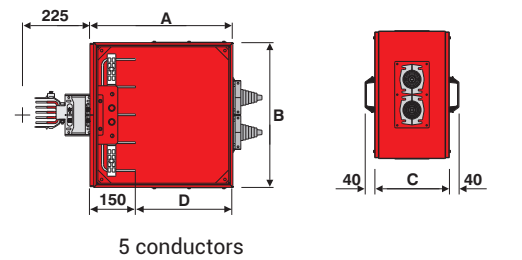

5 conductors

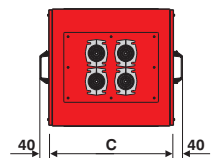

■ The dimensions given above are minimum values. ■ Please call us for special applications or for applications with MCCB's.

ELINEKX-II

►► Feeder Boxes (Central Feeder Boxes BO)

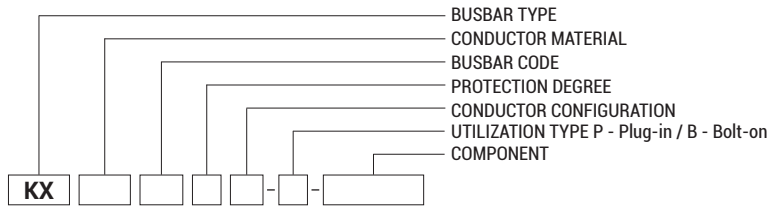

Cable Gland Plates

Busbar Housing Type	Cable Gland Plate	Type
		1
		2
		3
		2
		3
		4

Central Feeder Box - B O

Sample Order:
2500 A, Aluminium,
Bolt-on 4 conductors

KXA 25504 - B - BO

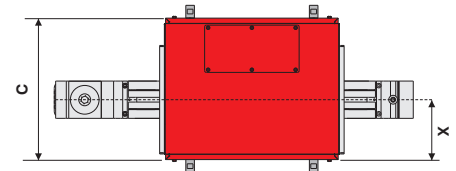
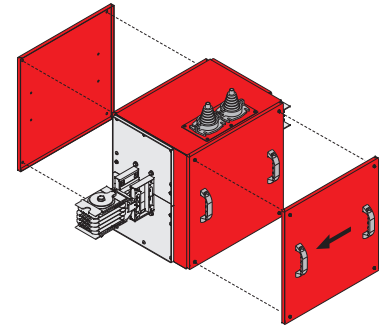

Ampere Ratings

KXA-II Al Conductor		KXC-II Cu Conductor		A	B	C	X	Gland Type
Rated Current	Busbar Code	Rated Current	Busbar Code	(mm)	(mm)	(mm)	(mm)	
-	-	*650	06	500	520 / 620*	405	175	1
-	-	*800	08	500	520 / 620*	405	175	1
630	06	-	-	500	520 / 620	405	175	1
-	-	*1000	10	500	520 / 620*	405	175	1
800	08	1250	12	500	520 / 620*	405	175	1
1000	10	-	-	500	520 / 620*	405	175	1
-	-	1350	14	500	520 / 620*	405	175	1
1250	12	1600	16	500	520 / 620*	405	175	1
-	-	2000	20	700	520 / 620*	805	277,5	1
1600	17	2250	21	700	520 / 620*	805	277,5	2
-	-	2500	25	700	520 / 620*	805	277,5	2
2000	20	-	-	700	520 / 620*	805	277,5	2
2500	27	-	-	700	520 / 620*	805	277,5	3
-	-	2250	24	700	520 / 620*	805	277,5	2
-	-	2750	28	700	520 / 620*	805	277,5	3
2350	21	3000	30	700	520 / 620*	805	277,5	3
2500	25	3300	32	700	520 / 620*	805	277,5	3
-	-	3600	36	700	520 / 620*	805	277,5	3
3000	32	4000	40	700	520 / 620*	805	277,5	3
3300	33	-	-	850	520 / 620*	1005	385	3
-	-	5000	50	850	520 / 620*	1005	385	3
4000	40	-	-	850	520 / 620*	1005	385	3
5000	51	-	-	850	520 / 620*	1005	385	3
-	-	6300	63	850	520 / 620*	1005	385	4
6300	63	-	-	850	520 / 620*	1005	385	4

*The values are given for 08 and 09 codes clean earth models.

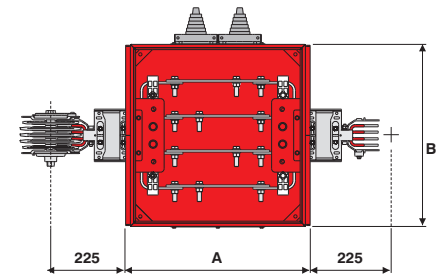

■ The dimensions given above are minimum values. ■ Please call us for special applications or for applications with MCCB's.

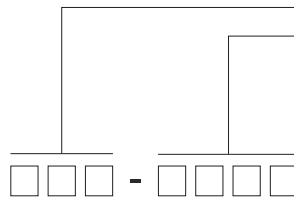

Supports

Description	Order Code
KX-II Vertical Riser Fixing Unit	3048475
KX-II Vertical Riser Fixing Unit (Fire Barrier)	3048707

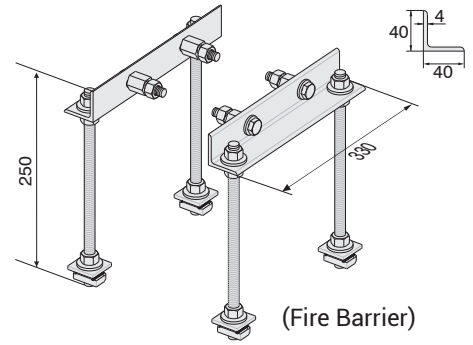
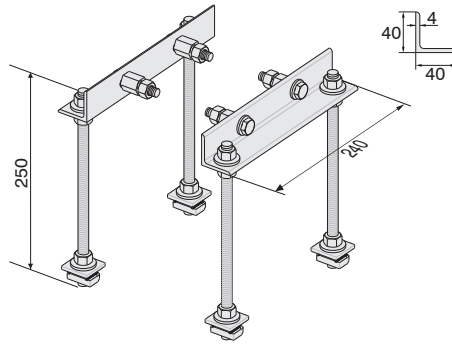
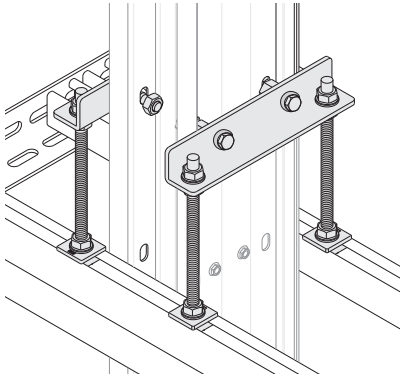

Description	Order Code
* KX-II Vertical Riser Fixing Unit	3305415
* KX-II Vertical Riser Fixing Unit (Fire Barrier)	3305419

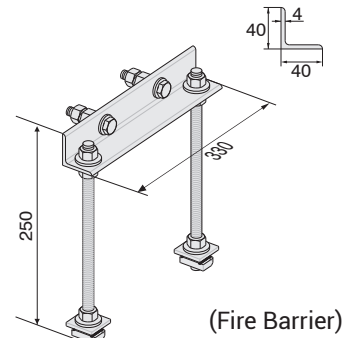
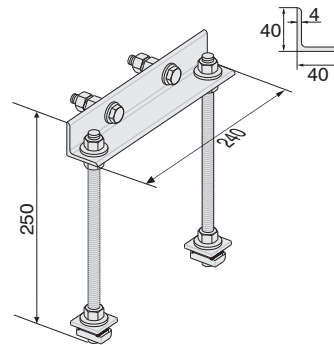
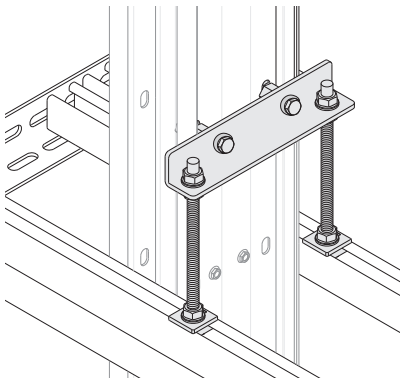

* KXA 04	* KXC 05	6x25
* KXA 05	* KXC 06	6x30
* KXA 06	* KXC 08	6x40

Fixing Elements

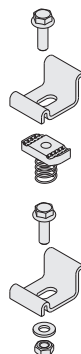

Description	Order Code
KX-II Fixing Clamp for Binrak (Unistrut) Channel	2011227

Description	Order Code
KX-II Fixing Clamp for Steel Angle Profile	2011226

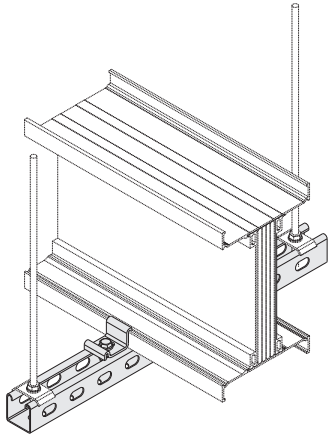
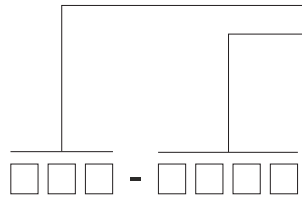

Supports

KX - BRA HANGER SET FOR EDGEWISE APPLICATION TO BINRAK (UNISTRUT) CHANNEL

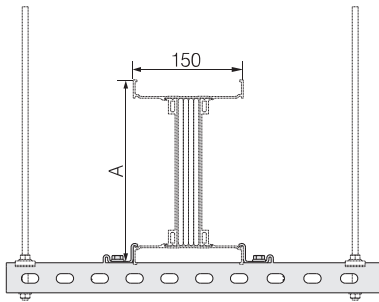
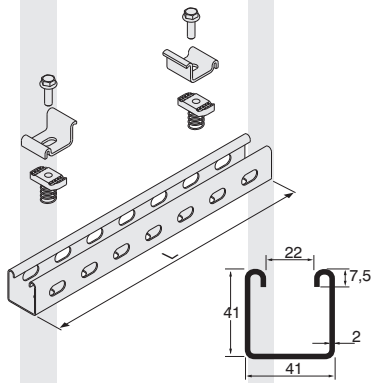

KX - BRA HANGER SET FOR FLATWISE APPLICATION TO BINRAK (UNISTRUT) CHANNEL

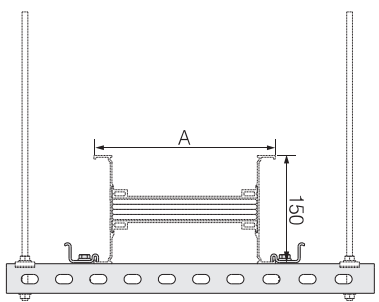
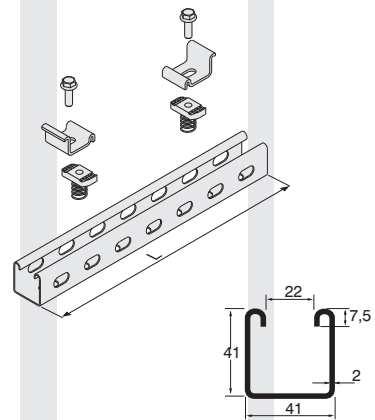
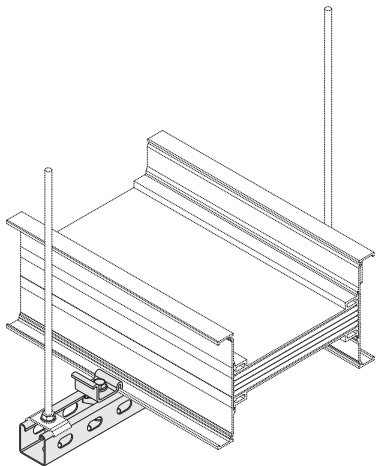

Al Conductor		Cu Conductor		L (mm)	A (mm)	Order Code
Rated Current	Busbar Code	Rated Current	Busbar Code			
-	-	650	06	350	77,5	3025372
-	-	800	08		82,5	
630	06	-	-		91	
-	-	1000	10		96	
800	08	1250	12		106	
1000	10	-	-		111	
-	-	1350	14		121	
1250	12	1600	16		131	
-	-	2000	20		161	
1600	16	2250	21		176	
-	-	2500	25		211	
2000	20	-	-		221	
2500	27	-	-	281		

Al Conductor		Cu Conductor		L (mm)	A (mm)	Order Code
Rated Current	Busbar Code	Rated Current	Busbar Code			
-	-	650	06	300	77,5	3025372
-	-	800	08		82,5	
630	06	-	-		91	
-	-	1000	10		96	
800	08	1250	12		106	
1000	10	-	-		111	
-	-	1350	14	121	3025373	
1250	12	1600	16	131		
-	-	2000	20	350	161	3025374
1600	16	2250	21	400	176	
-	-	2500	25	450	211	3025375
2000	20	-	-	450	221	
2500	27	-	-	450	281	

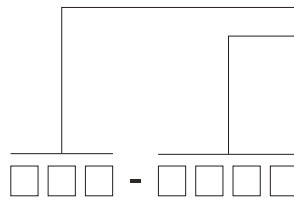
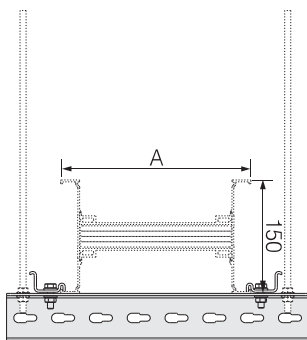
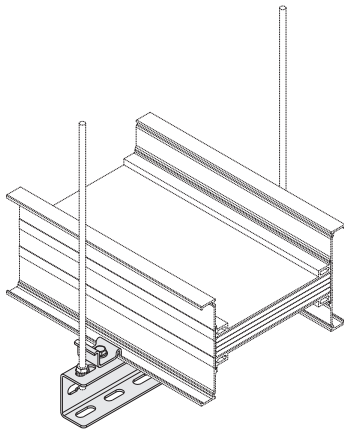
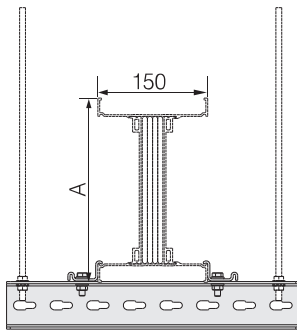
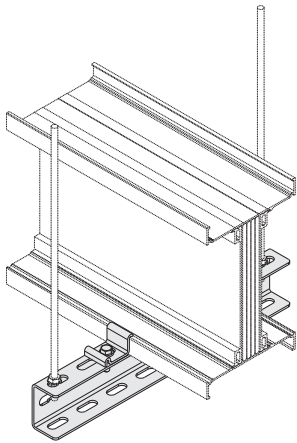

Supports

KX - UT HANGER SET FOR EDGEWISE APPLICATION TO NPU CHANNEL

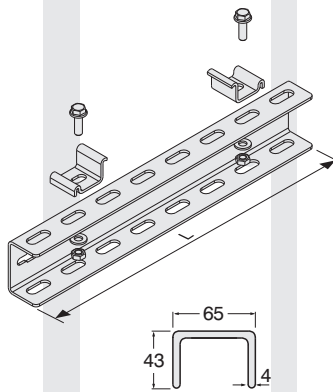

KX - UT HANGER SET FOR FLATWISE APPLICATION TO NPU CHANNEL

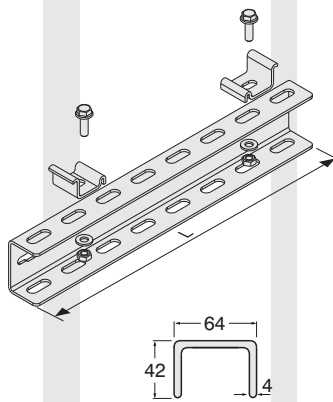

KXA-II Al Conductor		KXC-II Cu Conductor		L (mm)	A (mm)	Order Code
Rated Current	Busbar Code	Rated Current	Busbar Code			
-	-	650	06	350	77,5	3025348
-	-	800	08		82,5	
630	06	-	-		91	
-	-	1000	10		96	
800	08	1250	12		106	
1000	10	-	-		111	
-	-	1350	14		121	
1250	12	1600	16		131	
-	-	2000	20		161	
1600	17	2250	21		176	
-	-	2500	25		211	
2000	20	-	-		221	
2500	27	-	-		281	
-	-	2250	24		202	
-	-	2750	28		232	
2350	21	3000	30		252	
2500	25	3300	32		282	
-	-	3600	36		312	
3000	32	4000	40		342	
3300	33	-	-		372	
-	-	5000	50		412	
4000	40	-	-	432		
5000	51	-	-	592		
-	-	6300	63	612		
6300	63	-	-	732		

KXA-II Al Conductor		KXC-II Cu Conductor		L (mm)	A (mm)	Order Code
Rated Current	Busbar Code	Rated Current	Busbar Code			
-	-	650	06	300	77,5	3025347
-	-	800	08		82,5	
630	06	-	-		91	
-	-	1000	10		96	
800	08	1250	12		106	
1000	10	-	-		111	
-	-	1350	14		121	
1250	12	1600	16		131	
-	-	2000	20		161	
1600	17	2250	21		176	
-	-	2500	25	211		
2000	20	-	-	221		
2500	27	-	-	281		
-	-	2250	24	400	202	
-	-	2750	28	232		
2350	21	3000	30	450	252	
2500	25	3300	32	282		
-	-	3600	36	500	312	
3000	32	4000	40	550	342	
3300	33	-	-	372		
-	-	5000	50	600	412	
4000	40	-	-	432		
5000	51	-	-	592		
-	-	6300	63	800	612	
6300	63	-	-	900	732	

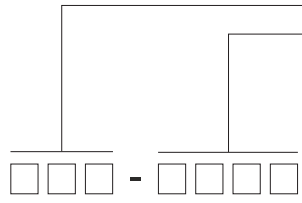

Supports

KX HANGER SET FOR EDGEWISE APPLICATION TO STEEL ANGLE PROFILE

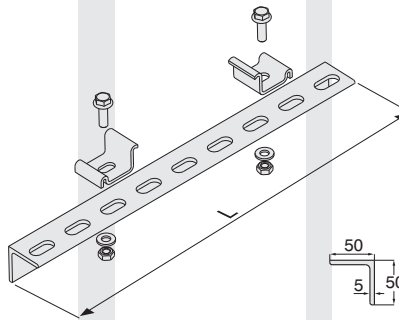
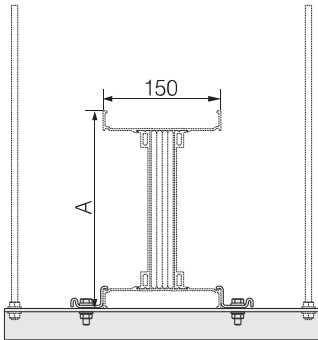
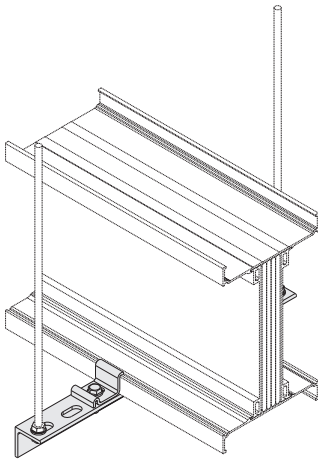

KX HANGER SET FOR FLATWISE APPLICATION TO STEEL ANGLE PROFILE

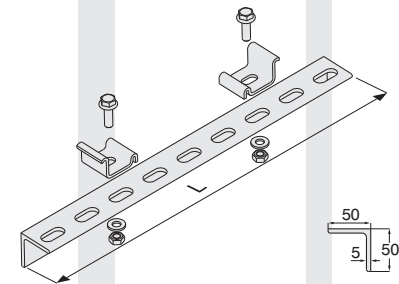
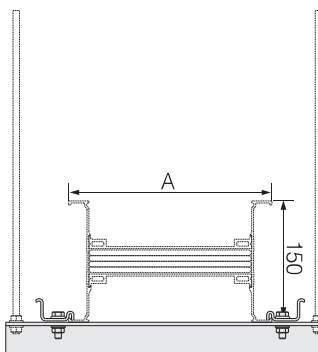
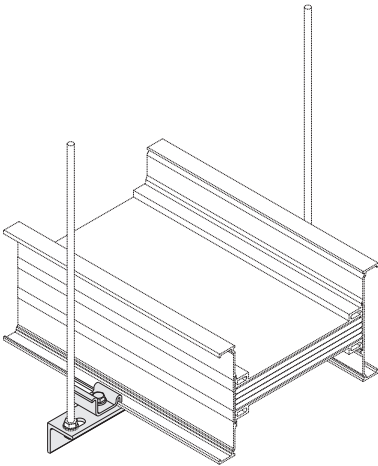

Al Conductor		Cu Conductor		L (mm)	A (mm)	Order Code
Rated Current	Busbar Code	Rated Current	Busbar Code			
-	-	650	06	350	77,5	3025344
-	-	800	08		82,5	
630	06	-	-		91	
-	-	1000	10		96	
800	08	1250	12		106	
1000	10	-	-		111	
-	-	1350	14		121	
1250	12	1600	16		131	
-	-	2000	20		161	
1600	16	2250	21		176	
-	-	2500	25		211	
2000	20	-	-		221	
2500	27	-	-		281	

Al Conductor		Cu Conductor		L (mm)	A (mm)	Order Code
Rated Current	Busbar Code	Rated Current	Busbar Code			
-	-	650	06	300	77,5	3025343
-	-	800	08		82,5	
630	06	-	-		91	
-	-	1000	10		96	
800	08	1250	12		106	
1000	10	-	-		111	
-	-	1350	14		121	
1250	12	1600	16		131	
-	-	2000	20		161	
1600	16	2250	21		176	
-	-	2500	25		211	
2000	20	-	-		221	
2500	27	-	-		281	

ELINEKX-II

►► Fixing Elements

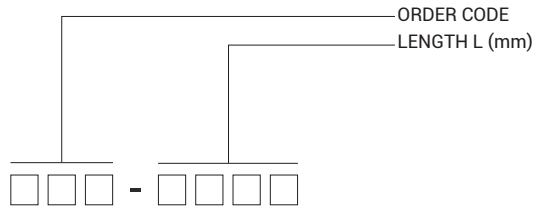
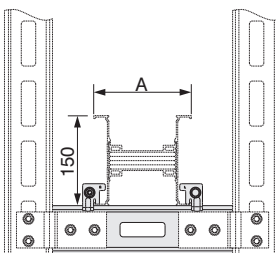
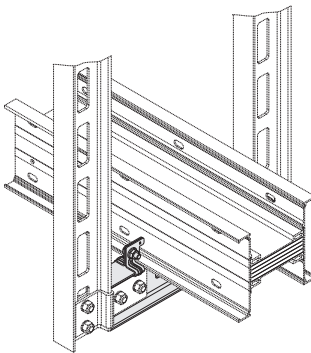
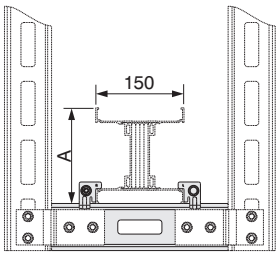
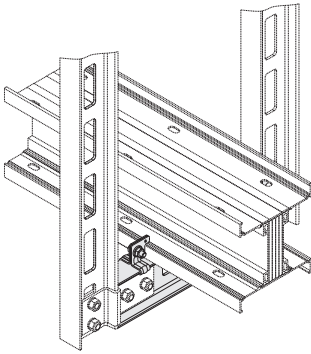
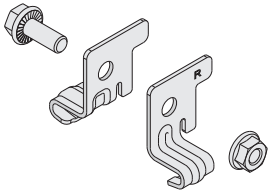

Supports

**KX - IDY TWO-WAY
FOR EDGEWISE
APPLICATION
TO NPI CHANNEL**

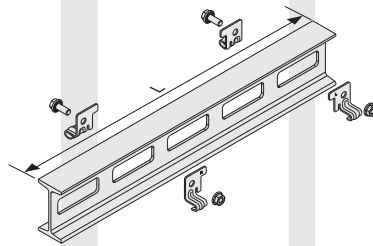

**KX - IDY TWO-WAY
FOR FLATWISE
APPLICATION
TO NPI CHANNEL**

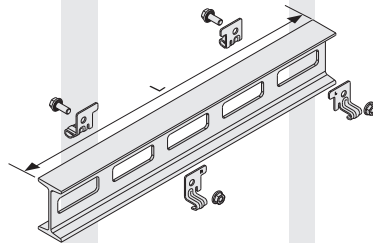

KXA-II Al Conductor		KXC-II Cu Conductor		L (mm)	A (mm)	Order Code
Rated Current	Busbar Code	Rated Current	Busbar Code			
-	-	650	06	300	77,5	3113547
-	-	800	08		82,5	
630	06	-	-		91	
-	-	1000	10		96	
800	08	1250	12		106	
1000	10	-	-		111	
-	-	1350	14		121	
1250	12	1600	16		131	
-	-	2000	20		161	
1600	17	2250	21		176	
-	-	2500	25		211	
2000	20	-	-		221	
2500	27	-	-		281	
-	-	2250	24		202	
-	-	2750	28		232	
2350	21	3000	30		252	
2500	25	3300	32		282	
-	-	3600	36		312	
3000	32	4000	40		342	
3300	33	-	-		372	
-	-	5000	50		412	
4000	40	-	-	432		
5000	51	-	-	592		
-	-	6300	63	612		
6300	63	-	-	732		

KXA-II Al Conductor		KXC-II Cu Conductor		L (mm)	A (mm)	Order Code		
Rated Current	Busbar Code	Rated Current	Busbar Code					
-	-	650	06	300	77,5	3113547		
-	-	800	08		82,5			
630	06	-	-		91			
-	-	1000	10		96			
800	08	1250	12		106			
1000	10	-	-		111			
-	-	1350	14		121			
1250	12	1600	16		131			
-	-	2000	20		161			
1600	17	2250	21		176			
-	-	2500	25		211			
2000	20	-	-		400		221	3113548
2500	27	-	-		500		281	3113549
-	-	2250	24		300		202	3113547
-	-	2750	28		400		232	3113548
2350	21	3000	30		500		252	3113549
2500	25	3300	32				282	
-	-	3600	36				312	
3000	32	4000	40		600		342	3113550
3300	33	-	-				372	
-	-	5000	50				412	
4000	40	-	-	700	432	3113550		
5000	51	-	-	700	592	3134127		
-	-	6300	63	900	612	3113553		
6300	63	-	-		732			

■ Please call us for non-standard components.

ELINEKX-II

►► Fixing Elements

ORDER CODE
LENGTH L (mm)

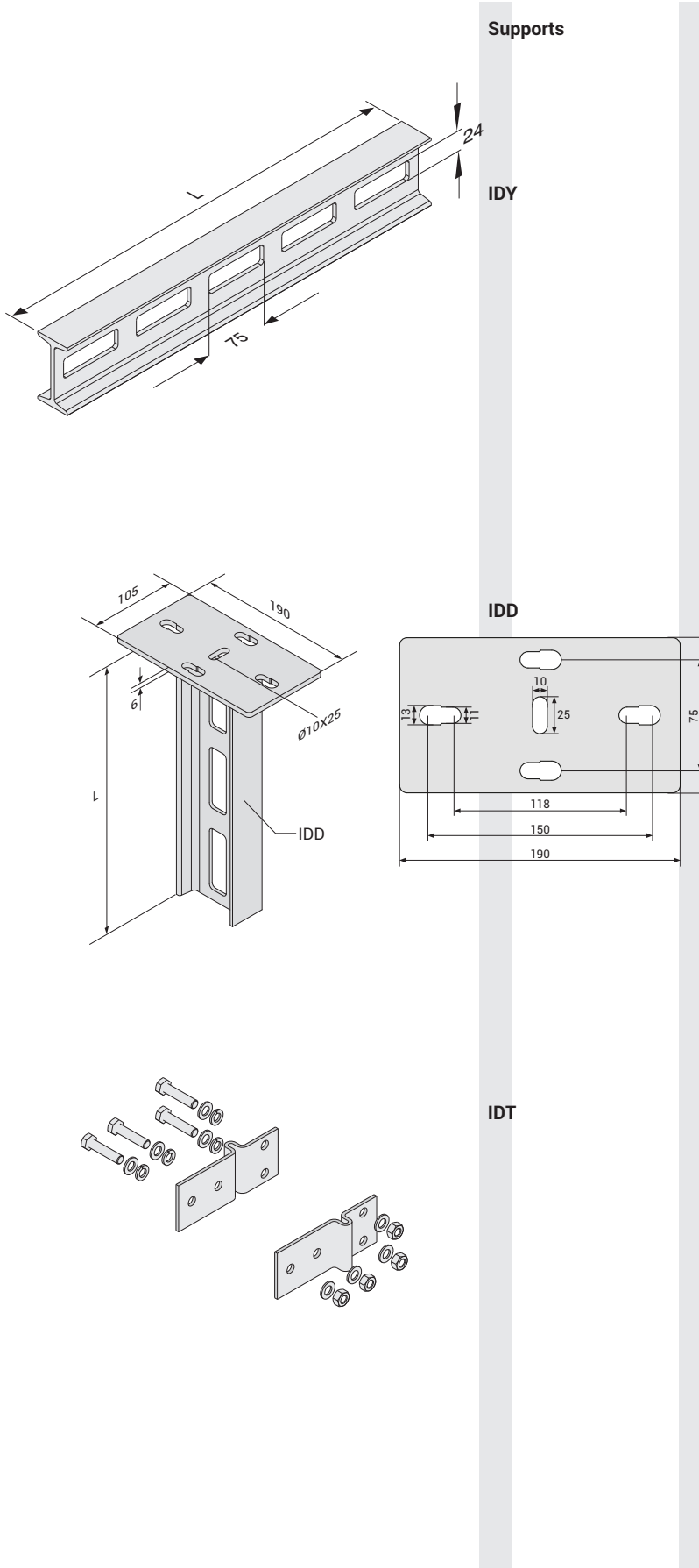

Description	L (mm)	Order Code
IDY 300	300	3008242
IDY 400	400	3008290
IDY 500	500	3008289
IDY 600	600	3008288
IDY 700	700	3008287
IDY 800	800	3008286
IDY 900	900	3008285
IDY 1000	1000	3008284
IDY 1100	1100	3008283
IDY 1200	1200	3008282
IDY 1300	1300	3008236
IDY 1400	1400	3008281
IDY 1500	1500	3008280
IDY 1600	1600	3008241
IDY 1700	1700	3008240
IDY 1800	1800	3008239
IDY 1900	1900	3008238
IDY 2000	2000	3008237
IDD 300	300	3008314
IDD 400	400	3008313
IDD 500	500	3008312
IDD 600	600	3008311
IDD 700	700	3008310
IDD 800	800	3008309
IDD 900	900	3008308
IDD 1000	1000	3008307
IDD 1100	1100	3008306
IDD 1200	1200	3008305
IDD 1300	1300	3008304
IDD 1400	1400	3008303
IDD 1500	1500	3008302
IDD 1600	1600	3008301
IDD 1700	1700	3008300
IDD 1800	1800	3008299
IDD 1900	1900	3008298
IDD 2000	2000	3008297
IDT Support Fitting	-	3008279

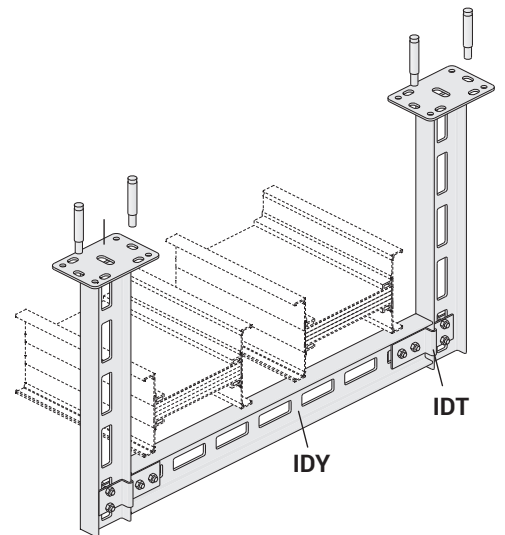

■ Please call us for non-standard components.

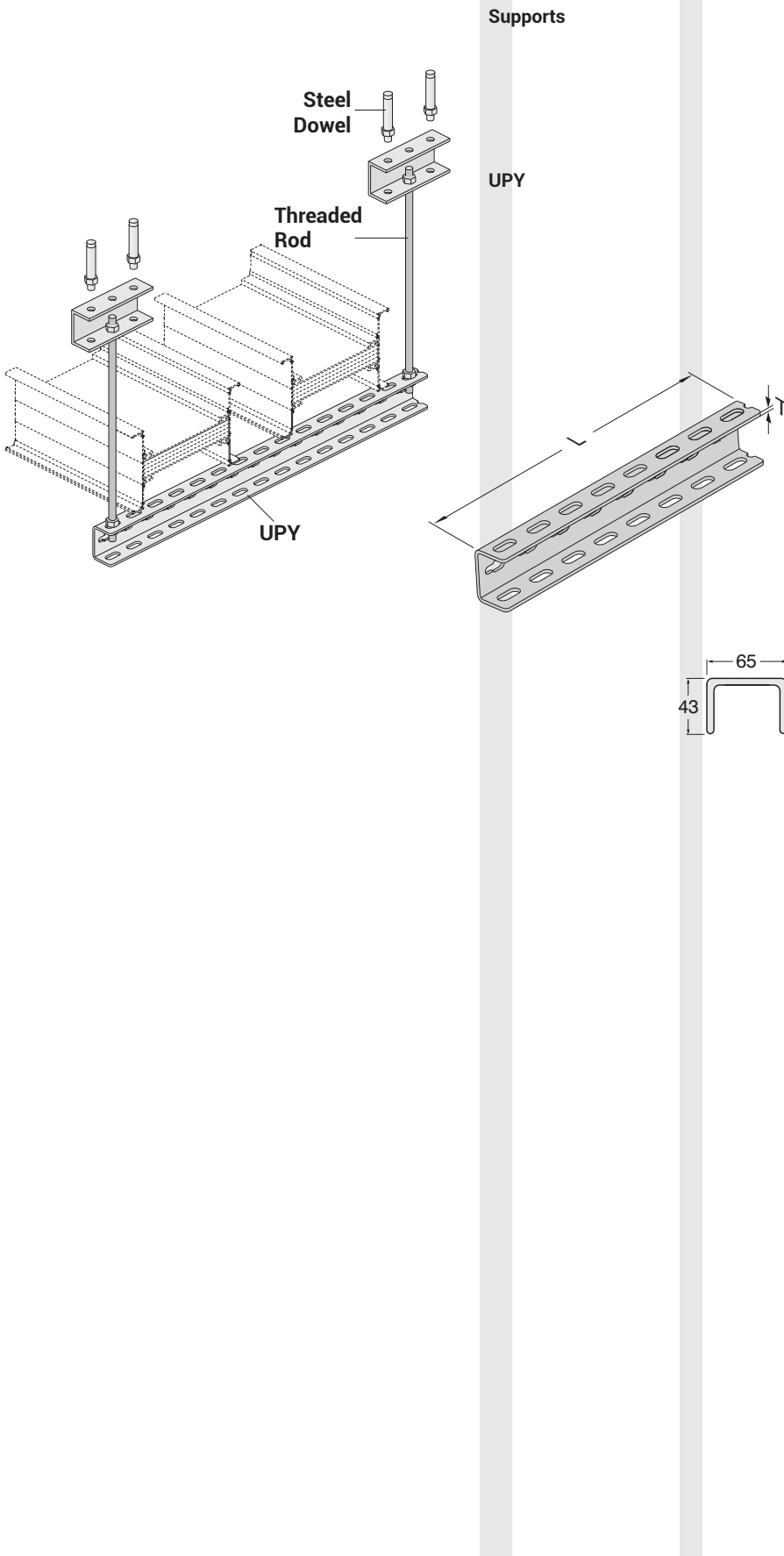

Description	T (mm)	L (mm)	Order Code
UPY 300	4	300	3004487
UPY 400	4	400	3004489
UPY 500	4	500	3004491
UPY 600	4	600	3004493
UPY 700	4	700	3004495
UPY 800	4	800	3004496
UPY 900	4	900	3004497
UPY 1000	4	1000	3004498
UPY 1100	4	1100	3004499
UPY 1200	4	1200	3004500
UPY 1500	4	1500	3004503

ELINEKX-II

►► Fixing Elements

ORDER CODE
LENGTH L (mm)

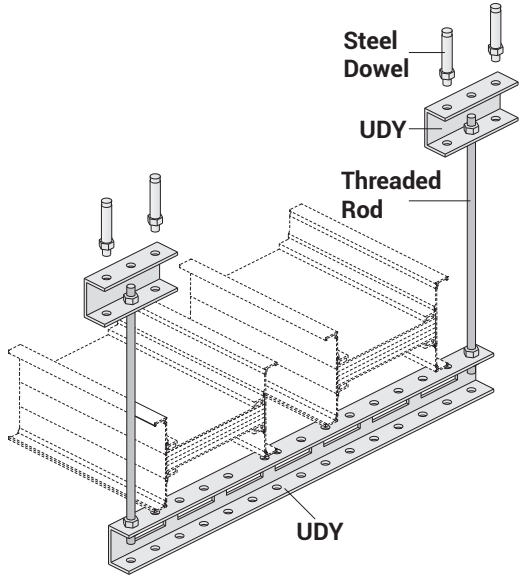
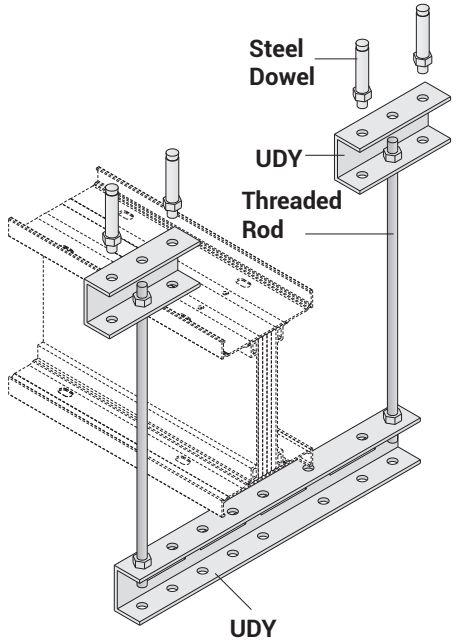
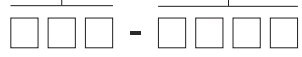

Supports

UDY

Description	L (mm)	Order Code
UDY 300	300	3008023
UDY 400	400	3008024
UDY 500	500	3008025
UDY 600	600	3008026
UDY 700	700	3008027
UDY 800	800	3008028
UDY 900	900	3008029
UDY 1000	1000	3008030
UDY 1100	1100	3008031
UDY 1200	1200	3008032
UDY 1300	1300	3008033
UDY 1400	1400	3008034
UDY 1500	1500	3008035
UDY 1600	1600	3008036
UDY 1700	1700	3008037
UDY 1800	1800	3008038
UDY 1900	1900	3008039
UDY 2000	2000	3008040

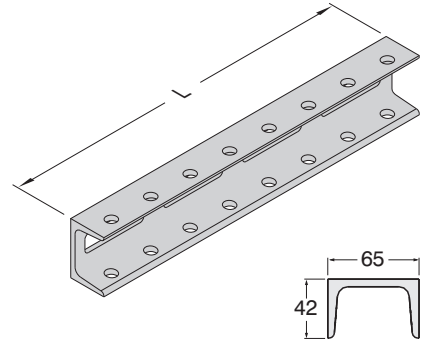

■ Please call us for non-standard components.

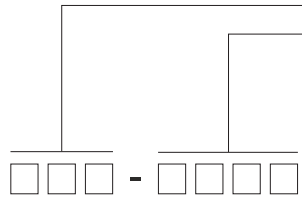
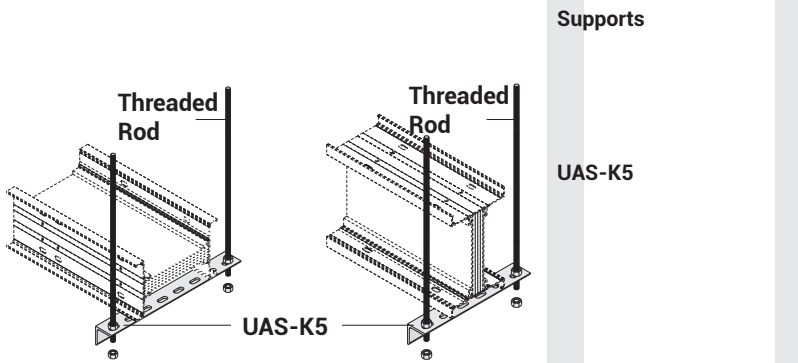

Description	L (mm)	Order Code
UAS-K5 SUPPORT (1)	200	3005324
UAS-K5 SUPPORT (2)	250	3005323
UAS-K5 SUPPORT (3)	300	3005322
UAS-K5 SUPPORT (4)	350	3005321
UAS-K5 SUPPORT (5)	400	3005320
UAS-K5 SUPPORT (6)	500	3005319
UAS-K5 SUPPORT (7)	600	3005318
UAS-K5 SUPPORT (8)	700	3005317
UAS-K5 SUPPORT (9)	1100	3005316

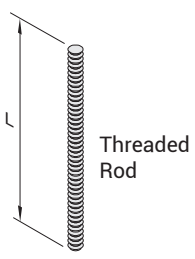
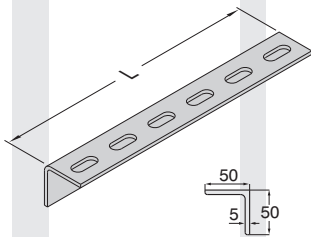

Connection Units

Description	L (mm)	Order Code
BRA 12-05 Threaded Rod (M10)	500	5000037
BRA 12-10 Threaded Rod (M10)	1000	5000032
BRA 14-05 Threaded Rod (M12)	500	5000026
BRA 14-10 Threaded Rod (M12)	1000	5000034
BRA 13 Extension Unit (M10)	-	1004312
BRA 13 Extension Unit (M12)	-	1004282
BRA 9 Steel Dowel (M10)	-	5000023
BRA 9 Steel Dowel (M12)	-	5000022
M10 Steel Nut	-	1000522
M12 Steel Nut	-	1000964
M10 Washer	-	1000504
M12 Pul	-	1000505

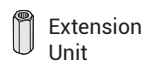

Extension Unit



Steel Dowel

Diameter of the hole to be drilled
M10.....Ø14
M12.....Ø16



Steel Nut



Washer

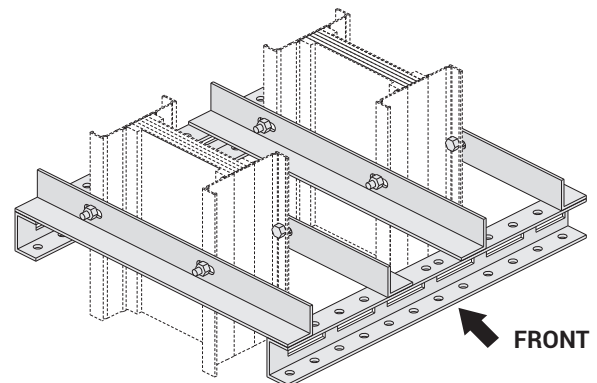

Vertical Riser Application
Sample Order Hanging
(Special to project)

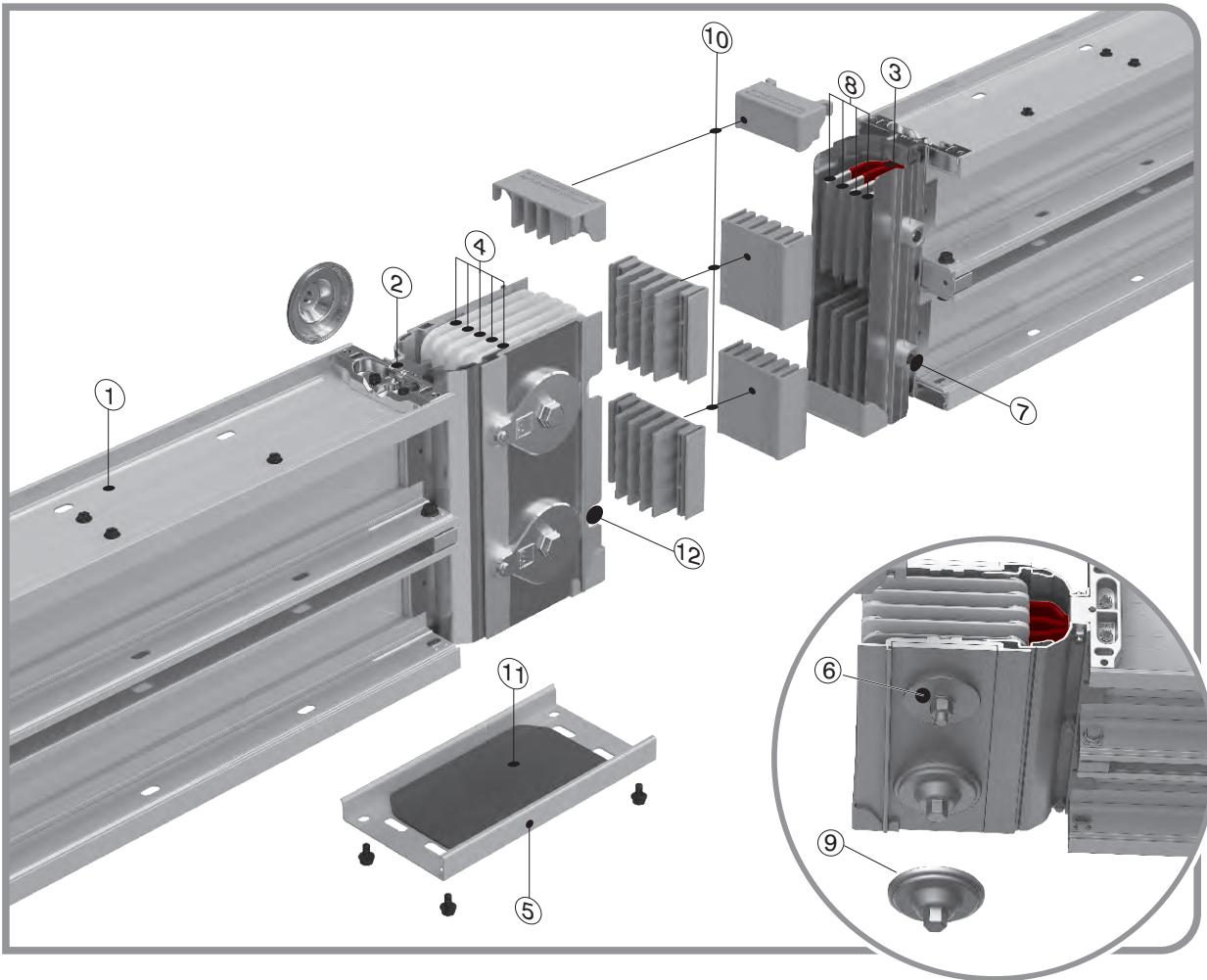

- 1- Extruded Aluminium Housing
- 2- PE Fixing Piece
- 3- Insulation Layers (Epoxy+B class polyester film)
- 4- Joint Insulators
- 5- Joint Cover
- 6- Belleville
- 7- Alignment Pin (removable)
- 8- Conductors
- 9- IP55 Nut Locking Piece
- 10- Protection Plastic
- 11- IP55 Joint Cover Gasket
- 12- Alignment Pin Slot

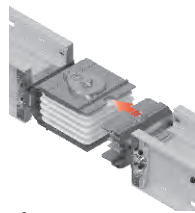

Figure 3

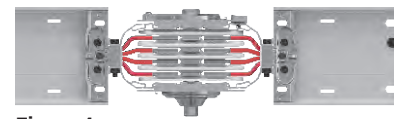

Figure 4 Joint assembly

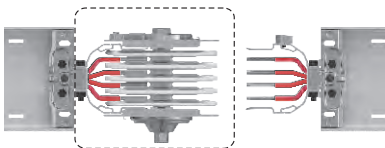

Figure 1 Block Joint

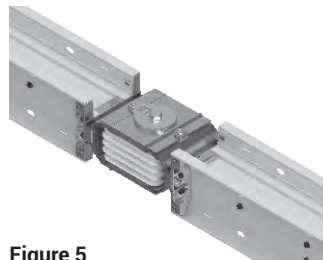

Figure 5

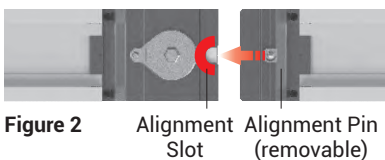

Figure 2 Alignment Slot Alignment Pin (removable)

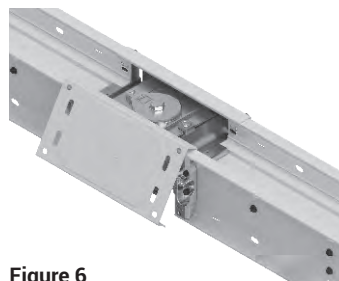
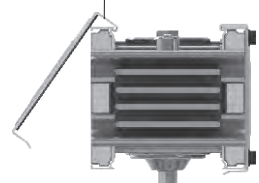

Figure 6

The joint cover is closed by leverage.



After installation of standard busbar 3m lengths, you will be in need of special lengths which are smaller than 3m. The minimum length for these special elements can be 35 cm. Please measure the lengths of these modules as shown below.

Length A is measured between housing of 2 busbars in cm. A The special length is calculated by deducting 25 cm from this measured length.

$X = A - 250$ (mm) $X =$ Length of Special Busbar (The busbar module will be manufactured as per X value.)

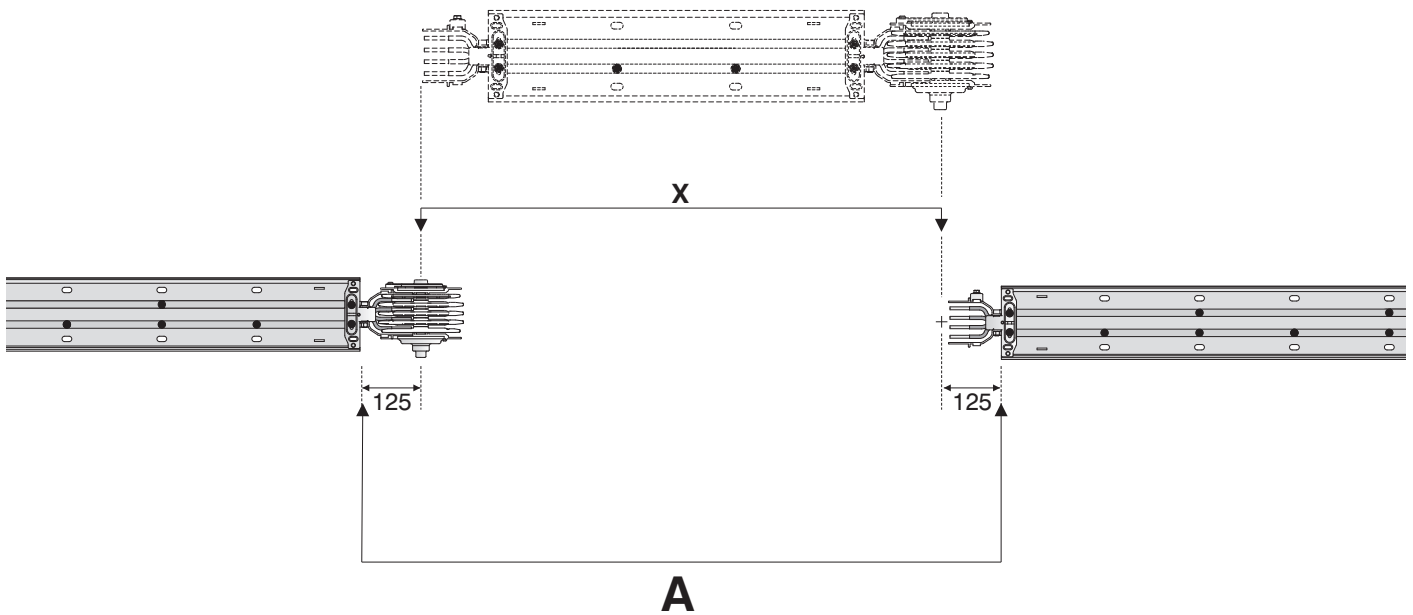

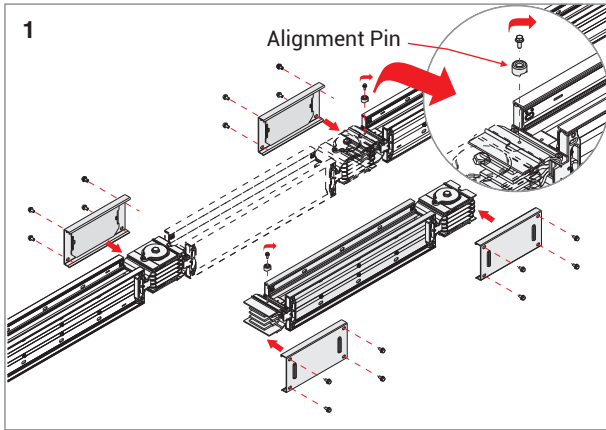

1- Remove Alignment Pin on the busbar, without block joint.

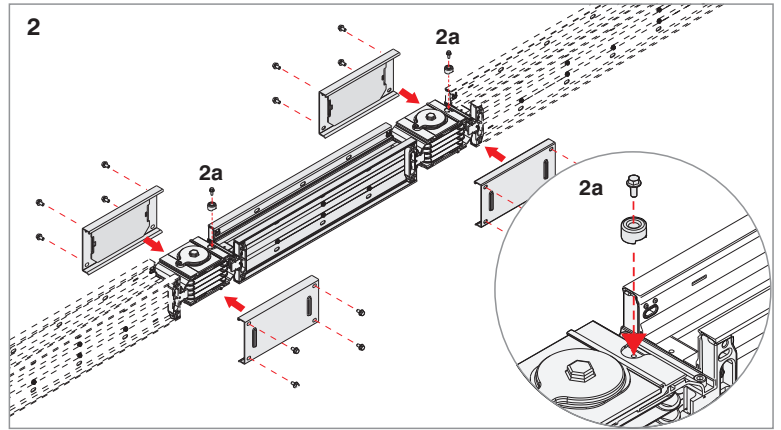

2- Insert the piece aligning conductors correctly. Fix back the Alignment pin.

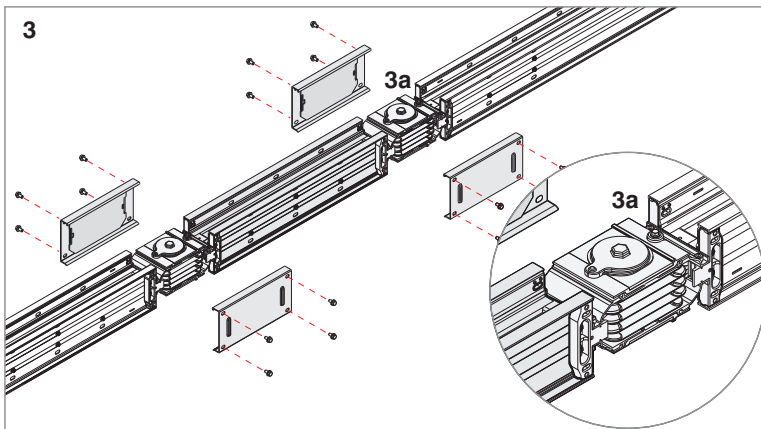

3- Make sure busbar piece is aligned according to alignment pin.

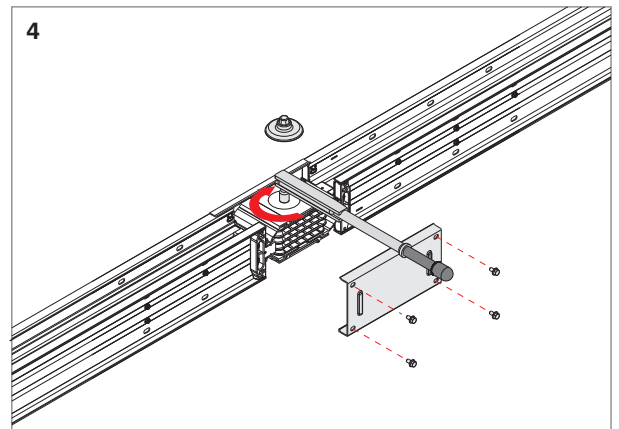

4- Fix one of the joint cover to stabilize joint. Apply 83Nm to the main bolt.

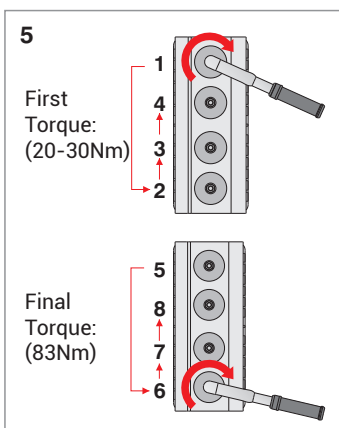

5- If there are more than one bolt for the same phase, bolts shall be tightened by hand approximately 20-30Nm as per above sequence, then 83Nm shall be applied at final torque with the same sequence.

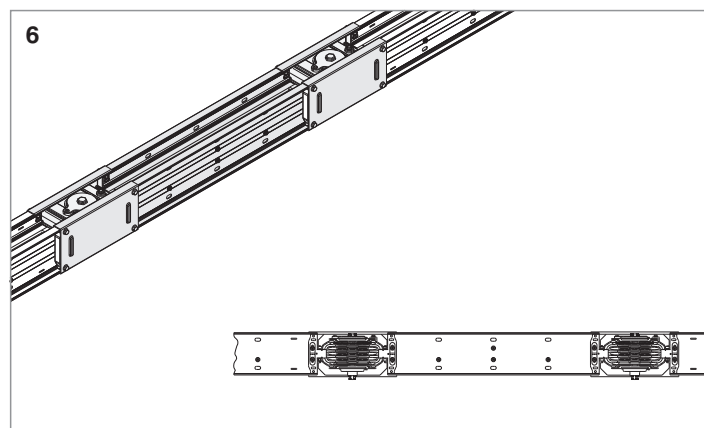

6- Fix the remaining joint cover. Joint installation is completed.

Note: If the final joint cover does not close correctly, it indicates the busbar is not completely aligned. Release the bolts and reapply the sequence from figure 4 to complete the joint.

CE DECLARATION OF CONFORMITY

Product Group E-Line KX-II Busbar Energy Distribution System

Manufacturer EAE Elektrik Asansor End. Insaat San. ve Tic. A.S.
Akcaburgaz Mahallesi, 3114. Sokak,
No:10 34522 Esenyurt-Istanbul

The objects of the declaration described below is in conformity with the relevant Union harmonisation legislation. This declaration of conformity is issued under the sole responsibility of the manufacturer.

Standard :**TS EN 61439-6**

Low-voltage switchgear and controlgear assemblies - Part 6: Busbar trunking systems

CE - Directive

2014/35/EU "The Low Voltage Directive"

2014/30/EU "(EMC) Elektromanyetik Uyumluluk Direktifi"

2011/65/EU "Restriction of the use of certain hazardous substances (RoHS)"

Technical Document Preparation Official:EAE Elektrik Asansor End. Insaat San. ve Tic. A.S.
Akcaburgaz Mahallesi, 3114. Sokak, No:10 34522 Esenyurt-Istanbul

Emre GÜRLEYEN

Date

20.04.2022

Document Authorized SignatoryElif Gamze KAYA OK
Deputy General Manager

630A ... 6300A COMPACT BUSBAR PRODUCT OVERVIEW (E-LINE KX-II)

1- Standards & Certification:

- Busbar system shall be designed and manufactured as per IEC 61439-6 standard, which requires below listed tests. Each busbar rating shall have a separate type test certificate from an independent internationally accredited laboratory including below tests: 10.2- Strength of material and parts, 10.2.2- Resistance to corrosion, 10.2.3- Properties of insulating materials, 10.2.3.1- Verification of thermal stability of enclosures, 10.2.3.2- Verification of resistance of insulating materials to abnormal heat and fire due to internal electric effects, 10.2.6- Mechanical impact, 10.2.7- Marking, 10.2.101- Ability to withstand mechanical loads, 10.2.101.1- Test procedure for a straight busbar trunking unit, 10.2.101.2- Test procedure for a joint, 10.2.101.3- Resistance of the enclosure to crushing, 10.3- Degree of protection of assembly, 10.4- Clearances and creepage distances, 10.5- Protection against electric shock and integrity of protective circuits, 10.5.2- Effective earth continuity between the exposed conductive parts of the assembly and the protective circuit, 10.5.3- Short-circuit withstand strength of the protective circuit, 10.9- Dielectric properties, 10.9.2- Power-frequency withstand voltage, 10.9.3- Impulse withstand voltage, 10.10- Verification of temperature rise, 10.11- Short-circuit withstand strength, 10.101- Resistance to flame propagation, 10.102- Fire resistance in building penetrations, Annex BB Phase conductor characteristics, Annex CC Fault-loop zero-sequences impedances, Annex DD Fault-loop resistances and reactances.
- Busbar system shall have CE marking.
- The manufacturer of busbar system shall have ISO 9001 and ISO 14001 certification.
- Each product shall have a "Type Label" including coding system, which identifies the brand, type of the unit, number of conductors and electrical details. The same coding shall be on the related certificate and catalogue.

2- Electrical Characteristics

- Busbar systems nominal insulation voltage shall be 1000 V.
- As per ampere rates, minimum short circuit values shall be as given below;

For Aluminium Conductors;		For Copper Conductors;	
630A	:1 sec/rms 25kA, Peak 52,5kA	650A	:1 sec/rms 24kA, Peak 50,4kA
800-1000A	:1 sec/rms 35kA, Peak 74kA	800A	:0,3 sec/rms 50kA, Peak 105kA
1250A	:1 sec/rms 50kA, Peak 105kA	1000A	:1 sec/rms 50kA, Peak 105kA
1600A	:1 sec/rms 70kA, Peak 154kA	1250A	:1 sec/rms 60kA, Peak 132kA
2000-2350-2500-3000-3300A	:1 sec/rms 100kA, Peak 220kA	1350A	:1 sec/rms 75kA, Peak 165kA
4000A and above	:1 sec/rms 120kA, Peak 264kA	1600-1900A	:1 sec/rms 85kA, Peak 187kA
		2000A-2250-2500A	:1 sec/rms 100kA, Peak 220kA
		2250-2750A	:1 sec/rms 110kA, Peak 242kA
		3000A	:1 sec/rms 150kA, Peak 330kA
		3300A and above	:1 sec/rms 180kA, Peak 396kA

2.1- Housing

- Busbar system shall have "Sandwich-Compact" structure. Conductors shall be packed and placed into the housing without leaving air gap in order to provide low reactance.
- Housing shall be made of thermal processed, extruded aluminium, RAL7038-Electrostatic painted.
- Compact structure of the housing shall be provided by M6 screws applied at every 19cm along the entire length.
- The sandwich-compact structure shall continue at the plug-in points too. There shall not be air gap between conductors at the plug-in points.

2.2- Conductors

- Aluminium or Copper conductors shall be epoxy coated and tin plated at the joints upon the wire configuration and required numbers, which are described below.
- Compact busbar system shall have aluminium conductors between 630A – 6300A.
- Compact busbar system shall have copper conductors between 650A – 6300A.
- Compact busbar system shall have the following number of conductors and wire configuration;
- 4 ½ Conductors: (4 full size conductors + PE (50% earth conductor + housing),
- 5 Conductors: (5 full size conductors + PE (100% earth conductor + housing),
- 6 Conductors: (6 full size conductors + CPE (100% earth conductor + housing),
- Phase conductors and neutral conductor shall have the same cross-section and they shall be insulated.
- Aluminium conductors shall be of EC grade aluminium. Minimum conductivity shall be 34m/mm² Ω
- Copper conductors shall be minimum 99,95% electrolytic copper. Minimum conductivity shall be 56m/mm² Ω

2.3- Insulation

- Insulation system shall be suitable for 1.000V continuous operation. Conductors shall be minimum thermo-set epoxy coated. Conductor size shall be designed so that temperature rise on the conductors shall not exceed 130C degree at nominal current, which helps to global heating problem. With this reason, insulation class shall be "B class".

2.4- Joint Structure

- Electrical and mechanical connection shall be made by placing conductor joints into the joint blocks of the connected conductors and followed by tightening and fastening of the joint bolts.

2.5- Protection

- Protection degree of the housing and joints shall be IP55/IP65.
- IP65 are not recommended for outdoor applications. Please check CR catalog.

2.6- Accessories

- Busbar system shall have all necessary accessories (elbows, offsets, panel-transformer connections, reductions, etc.) Manufacturer shall supply special dimensioned units in short time, if the project conditions requires.
- For horizontal runs, a horizontal expansion unit shall be used at every 40m and expansion points of the building.
- For vertical applications, a vertical expansion unit shall be used at every floor. Busbar system shall be rigidly fixed by supports at every floor.

3- Tap Off Boxes

- Both, Feeder and Plug-in busbar systems shall be suitable for bolt-on type tap off box connections at the joints up to 1.000A.
- Bolt-on tap off boxes shall be installed to the joints without changing or adding any piece. Bolt-on tap off boxes shall be able to be moved between different rated busbars.
- Plug-In busbars shall have minimum 2 plug-in points on each 300cm length. Plug-in tap off box sizes shall be up to 630A. Unused plug-in points shall have covers, which can provide IP55 protection degree.
- Plug-in tap off boxes shall be suitable to install or removed from busbars without switching off the power on the busbar.
- Contacts of plug-in tap off box shall be plated by silver.
- Tap off boxes shall be manufactured of sheet steel and epoxy painted RAL3020 colour.
- Plug-in tap off boxes shall have electromechanical safety interlock system. Which means;
- a-) Electromechanical interlock mechanism shall ensure that the tap off box cannot be removed mechanically from the busbar, when the switch is at "ON" position.
- b-) Electromechanical interlock mechanism shall ensure that, cover of the box can be opened only, when the switch is at "OFF" position.
- c-) When the cover is opened, inside protection degree shall be minimum IP2X against accessing to live conductors.
- d-) While inserting the contacts of plug-in tap off box, earth contact shall make the first touch. While removing, it shall be disconnected last.
- Tap off boxes shall be suitable for any brand of MCCBs. Electromechanical interlock mechanism shall be suitable for all these MCCBs too.

4- Installation and Commissioning

- Busbar systems shall be installed as per Single-Line drawings respect to required ampere rates and manufacturer installation guide (torque values, lockers, etc.). Electrical installer shall run an insulation test after installation according to manufacturers test procedures. The results of the test shall be reported to the manufacturer. Minimum insulation value shall be 1 Mohm.

Component List		Quantity
Item	Component	

Company :
Project :
Project No :

Name :
Date :
Signature :

Prepared by



Please duplicate this page for your own use.

EAE Elektrik A.S.
Head Office
Akcaburgaz Mahallesi,
3114. Sokak, No:10 34522
Esenyurt - Istanbul - TURKEY
Tel: +90 (212) 866 20 00
Fax: +90 (212) 886 24 20

EAE DL 3 Factory
Busbar
Gebze IV Istanbul Makine ve Sanayicileri
Organize Bolgesi, 6. Cadde,
No: 6 41455 Demirciler Koyu,
Dilovası - Kocaeli - TURKEY
Tel: +90 (262) 999 05 55
Fax: +90 (262) 502 05 69

Please visit our website for the updated version of our catalogues.
www.eaeelectric.com



Catalogue 47-Eng. / Rev 13 00 pcs. 03/07/2024
D.S.

EAE has full right to make any revisions or changes on this catalogue without any prior notice.

